

2010

General Case for Deriving Four Pole Coefficients for Gas Pulsation

Nasir Bilal

Purdue University

Douglas Adams

Purdue University

Keith Novack

Trane - Ingersoll Rand

Jack Sauls

Trane - Ingersoll Rand

Follow this and additional works at: <http://docs.lib.purdue.edu/icec>

Bilal, Nasir; Adams, Douglas; Novack, Keith; and Sauls, Jack, "General Case for Deriving Four Pole Coefficients for Gas Pulsation" (2010). *International Compressor Engineering Conference*. Paper 2036.
<http://docs.lib.purdue.edu/icec/2036>

This document has been made available through Purdue e-Pubs, a service of the Purdue University Libraries. Please contact epubs@purdue.edu for additional information.

Complete proceedings may be acquired in print and on CD-ROM directly from the Ray W. Herrick Laboratories at <https://engineering.purdue.edu/Herrick/Events/orderlit.html>

A Hybrid Approach of Calculating Gas Pulsations in the Suction Manifold of a Reciprocating Compressor

Nasir Bilal^{1*}, Prof. Douglas E. Adams¹, Keith Novak², Jack Sauls²

¹Purdue University, Department Mechanical Engineering,
West Lafayette, IN, USA
Purdue University Center for Systems Integrity
1500 Kepner Rd., Lafayette, IN 47905
Phone: 765 446 1709, bilal@ecn.purdue.edu

²Trane - Ingersoll Rand,
3600 Pammel Creek Rd, La Crosse, WI 54601 USA
Phone: (608)787-4105, Keith.Novak@trane.com

* Corresponding Author

ABSTRACT

A hybrid approach of calculating the gas pulsations in the suction manifold of a reciprocating compressor is developed using four pole parameters derived from Finite Element Analysis (FEA) and acoustic analytical model. Pressure response functions are used to calculate the four pole parameters of an acoustic cavity using FEA software (ANSYS). The four pole parameters are then used with an analytical model to calculate the pressure response in the acoustic cavity. The same scheme is then extended to a case of multiple inputs, and the resulting pressure response is compared to the results obtained with a Computational Fluid Dynamics (CFD) model. The Finite Element (FE) four pole approach produces more accurate results than the 1D wave equation analytical model because the FE four pole parameters method does not require geometric simplification and, thus, provides better estimates of the pressure response. The FE four pole approach can be easily extended to complex geometric shapes of suction and discharge manifolds. In addition, the four pole approach was preferred over the CFD method of modeling gas pulsations because the CFD model was computationally very expensive. The FE four pole parameters can be used inside a compressor simulation model to better model the flow of gasses through the valve and cylinder.

1. INTRODUCTION

The performance of a reciprocating compressor is strongly influenced by valve dynamics and mass flow into the compressor, which produce pressure pulsations in the suction manifold, generate noise, and reduce the efficiency of the compressor. Pressure pulsations response, or wave shapes are generated due to the intricate geometry and passages of the compressor manifold. Mathematical models developed earlier (Park, 2004) were used to predict the gas pulsation in the suction manifold. However, because of the complicated shape of the compressor manifold, many simplifying assumptions were made in the models to predict the pressure response mathematically.

The hybrid approach consist of using the finite element harmonic response solution using acoustic elements to calculate the four pole parameters of the acoustic cavity which is then used in an analytical model to calculate the pressure response in the cavity. Four pole parameters are based on the geometric characteristics of the system, the density of the gas, and the speed of sound. Therefore, 3D modeling of the acoustic cavity results in a more accurate calculation of the four pole than the 1D wave equation analytical model. Thus, the hybrid approach of using a finite element model together with an acoustic analytical model implemented in MATLAB produces a more accurate

pressure response because no geometric simplifications are used. The acoustic analytical model calculates the pressure at both ends of the system from the four pole parameters and mass flow of the system.

2. FOUR POLE METHOD

Four pole parameters are useful for the analysis of composite acoustic systems and are widely used to analyze gas pulsation in cavities (Soedel, 2006). In essence, the four pole technique expresses the flow conditions at one end of the cavity as a function of the conditions at the other end of the cavity. The four poles of a simple tube shown in the Fig. 1 are defined as

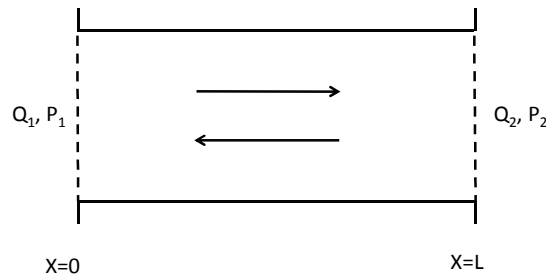

Figure 1: Configuration of a constant area tube.

$$\begin{Bmatrix} Q_1 \\ P_1 \end{Bmatrix} = \begin{bmatrix} A & B \\ C & D \end{bmatrix} \begin{Bmatrix} Q_2 \\ P_2 \end{Bmatrix} \quad (1)$$

where subscript 1 and 2 indicate the input and output ports, Q and P are complex harmonic amplitudes of the volume flow, velocity, and pressure, and A , B , C , and D are called the four poles and are defined as follows:

$$A = \cosh \gamma L = D \quad (2)$$

$$B = \frac{j\omega S}{\rho_0 c_0^2} \sinh \gamma L \quad (3)$$

$$C = \frac{\rho_0 c_0^2 \gamma}{j\omega S} \sinh \gamma L \quad (4)$$

where ρ , c , γ , L , are fluid density, speed of sound, the complex wave number and the length of the tube, respectively. The four pole parameters for any acoustic cavity are calculated using the pressure response functions, which are described next.

3. PRESSURE RESPONSE FUNCTIONS

A Pressure Response Function (PRF) f_{ij} (Singh and Soedel, 1978; and Kadam, 2005) for any general location is defined as the ratio of pressure induced at point i , denoted by P_i , due to the flow input, denoted by Q_j , inward to the cavity at point j , while the other side of the cavity is blocked as shown in Fig. 2.

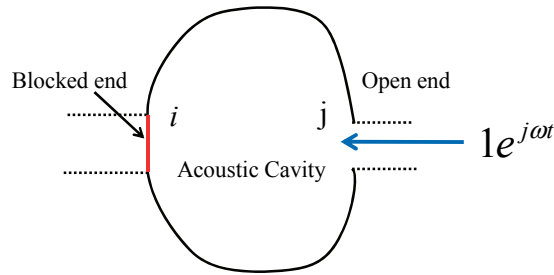

Figure 2: Illustration of generation of pressure response functions.

The PRF f_{ij} can be written as

$$f_{ij} = \frac{P_i}{Q_j} \quad (5)$$

where P_i is the pressure measured at location i , by blocking location i while applying a unit inward volume flow Q_j at point j . For any acoustical cavity, two runs of the FEA simulation are needed to determine the four PRFs of that cavity. Two PRFs, f_{12} and f_{22} , are calculated by a single run of experimental or numerical simulations. For a simple acoustic cavity as shown in Fig. 2, the PRFs can be written in the following form,

$$\begin{Bmatrix} P_1 \\ P_2 \end{Bmatrix} = \begin{bmatrix} f_{11} & f_{12} \\ f_{21} & f_{22} \end{bmatrix} \begin{Bmatrix} Q_1 \\ Q_2 \end{Bmatrix} \quad (6)$$

Equation (1) and (6) define the relationship between the same set of variables but are expressed differently. It can be shown that the four pole parameter can be formulated from PRFs of any acoustic system by extracting the following relationships:

$$A = \frac{f_{22}}{f_{12}}, \quad B = \frac{1}{f_{21}}, \quad C = -f_{12} + \frac{f_{11}}{f_{12}} f_{22}, \quad D = \frac{f_{11}}{f_{12}}$$

The finite element method based on simulations was used to calculate the four poles of the suction cavity as describe below.

4. COMPARISON OF FOUR POLE PARAMETERS CALCULATED BY 1D WAVE EQUATION AND THE FINITE ELEMENT METHOD

The procedure to determine the four pole coefficients of the actual suction manifold is outlined below:

- i. Model the gas passage of a simple suction manifold, Fig. 3 below, in ANSYS using acoustic element (Fluid30)
- ii. Apply loading conditions as in Fig. 2 (Two loading cases)
- iii. Perform harmonic analysis in ANSYS through the frequency range of interest
- iv. Determine the four pole coefficients using Improved Four Pole Method (Wu and Zhang, 1998).

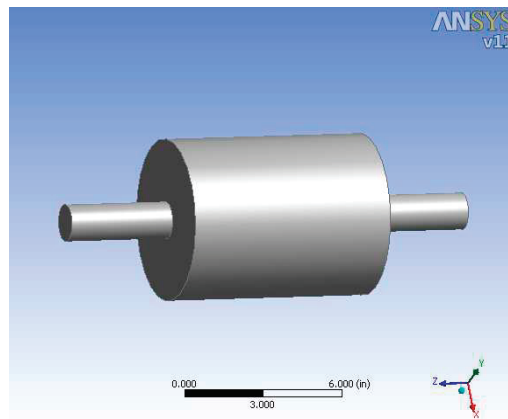

Figure 3: A simple muffler modeled in the ANSYS.

The results of the FE four pole terms calculated from method described above were compared with the four poles computed using the 1D analytical wave equation. Figure 4 shows the results. The FE four pole terms and the 1D analytical wave equation four pole terms are in relatively good agreement.

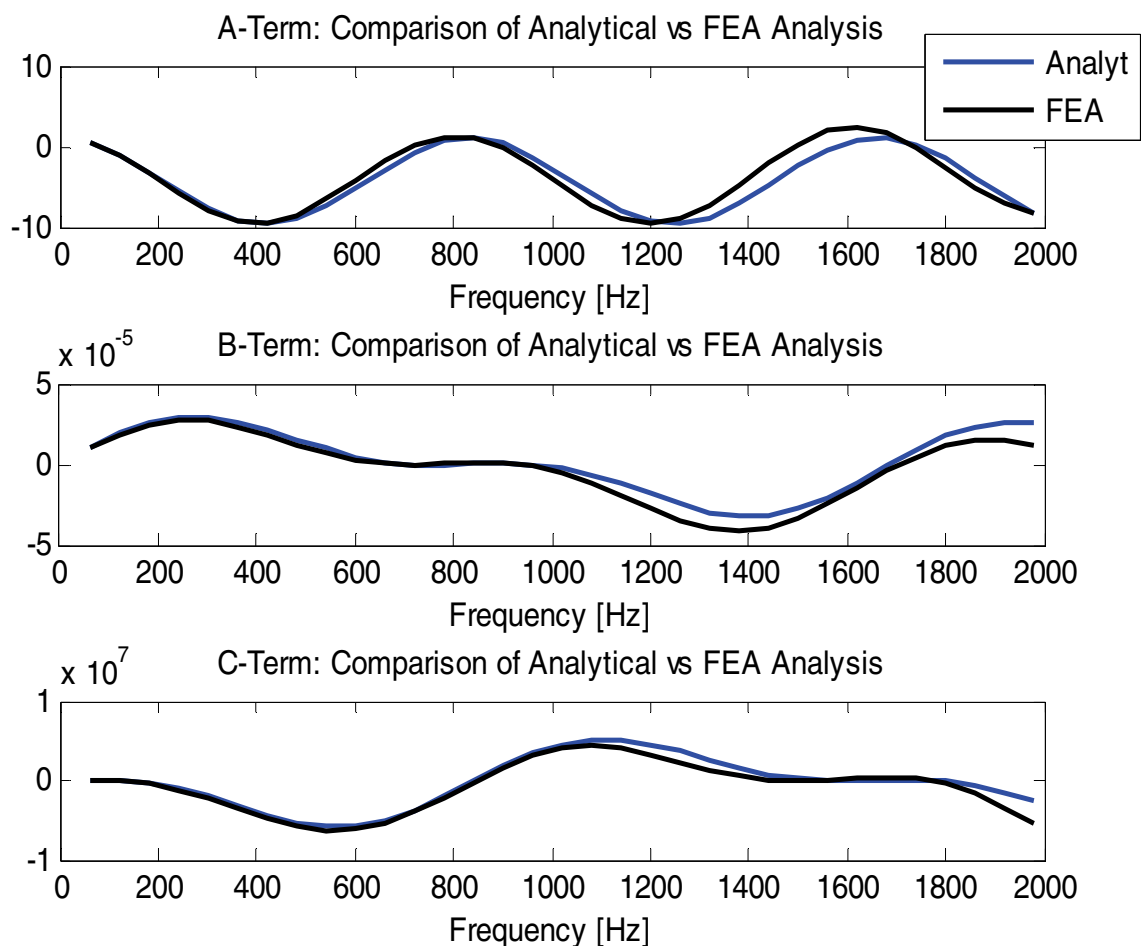

Figure 4: A comparison of A, B, and C terms of Analytical results with FEA results

5. GENERAL FORMULATION OF FOUR POLE PARAMETERS FOR MULTIPLE INPUTS

After comparing the results for the simple muffler model, shown in Fig. 3, the 1D wave equation model was extended to multiple inputs, shown in Fig. 5. This model can be considered a simplified model of a multi-cylinder compressor. First, the 1D wave equation analytical model was derived for the multiple tube configuration, shown in Fig. 5 below, to calculate the pressure response P_{L11} and P_{M11} at the valve location shown in Fig. 5.

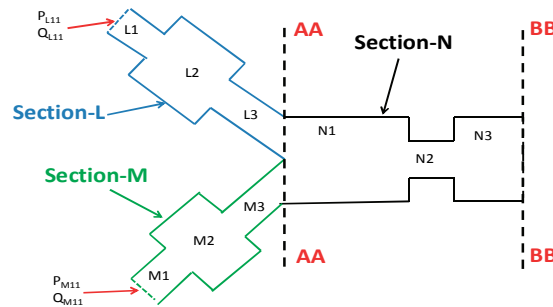

Figure 5: Schematic of a multi-cylinder compressor with each section consisting of several tubes connected in series.

Equation (7) and (8) show the expressions for pressure at location L_l and M_l . The expressions for P_{L11} and P_{M11} have been simplified by enforcing the pressure and volume continuity at the junction AA and BB and as explained in (Soedel, 2006).

$$P_{L11} = -\frac{C_L}{A_M} Q_{M11} + \left(C_L + D_L Z_{N11} + \frac{C_L}{A_M} B_M Z_{N11} \right) \left(\frac{A_M Q_{L11} + A_L Q_{M11}}{A_M A_L + A_M B_L Z_{N11} + A_L B_M Z_{N11}} \right) \tag{7}$$

$$P_{M11} = -\frac{C_M}{A_L} Q_{L11} + \left(C_M + D_M Z_{N11} + \frac{C_M}{A_L} B_L Z_{N11} \right) \left(\frac{A_L Q_{M11} + A_M Q_{L11}}{A_M A_L + A_L B_M Z_{N11} + A_M B_L Z_{N11}} \right) \tag{8}$$

In above expressions for the A_L, B_L, C_L and D_L are the global four pole parameter for tube section L as shown in Eq. (9)

$$\begin{bmatrix} A_L & B_L \\ C_L & D_L \end{bmatrix} = \begin{bmatrix} A_{L1} & B_{L1} \\ C_{L1} & D_{L1} \end{bmatrix} \begin{bmatrix} A_{L2} & B_{L2} \\ C_{L2} & D_{L2} \end{bmatrix} \begin{bmatrix} A_{L3} & B_{L3} \\ C_{L3} & D_{L3} \end{bmatrix} \tag{9}$$

Similarly, for section M and N, we can write

$$\begin{Bmatrix} Q_{M11} \\ P_{M11} \end{Bmatrix} = \begin{bmatrix} A_M & B_M \\ C_M & D_M \end{bmatrix} \begin{Bmatrix} Q_{M32} \\ P_{M32} \end{Bmatrix} \tag{10}$$

$$\begin{Bmatrix} Q_{N11} \\ P_{N11} \end{Bmatrix} = \begin{bmatrix} A_N & B_N \\ C_N & D_N \end{bmatrix} \begin{Bmatrix} Q_{N32} \\ P_{N32} \end{Bmatrix} \tag{11}$$

where, A_M, B_M, C_M , and D_M and A_N, B_N, C_N and D_N , are the global four pole parameters for section M and N . Q_{L11} and Q_{M11} are the mass flow rates at the inlet at section L and M respectively and are shown in Fig. 7 and Fig. 8. Z_{N11} is defined in Eq. (12)

$$Z_{N11} = \frac{P_{N11}}{Q_{N11}} = \frac{C_N}{A_N} \quad (12)$$

Equations (7) and (8) were used to calculate the pressure response in the cavities as shown in Fig. 5.

An FE model with multiple inputs was created in ANSYS, see Fig. 6, to compare the results from the 1D wave equation solution for multiple inputs to the FE four pole strategy. However, because the basic FE four pole formulation allows only one input and one output, it could not be used and a new strategy was needed for multiple inputs. The basic four pole formulation required only one input and one output. This new design had two inputs and one output. One option was to cut the design into pieces at Section AA in Fig. 5 and perform similar calculations as above, however real life compressors are not this simple. Work done by Singh and Soedel in 1979, Eq (13,14 and 15) showed the pressure at P_{L11} was affected by the mass flow through point P_{L11} , the mass flow through point P_{M11} and, the mass flow through section BB. The FE methods as described above was used to calculate both the Input Impedance and Transfer Impedance which are then used in Equation 15 to calculate the pressure at each input. This has allowed the formation of a new FE hybrid modeling technique that allows for multiple inputs; however the matrix is no longer a 2x2. In the case for Fig. 6, the matrix is a 3x3. This matrix can be solved by knowing the two input mass flows and a pressure boundary condition at the outlet.

Input Impedance

$$\tilde{Z}_{qq}(n\omega) = \tilde{p}_q(n\omega)/\tilde{X}_q(n\omega) \quad q = 1,2,\dots,k \quad (13)$$

Transfer Impedance

$$\tilde{Z}_{qr}(n\omega) = \tilde{p}_q(n\omega)/\tilde{X}_r(n\omega) \quad q \neq r \quad r = 1,2,\dots,k \quad \text{and} \quad q = 1,2,\dots,k \quad (14)$$

$$\tilde{p}_{v1}(n\omega) = \tilde{Z}_{11}(n\omega)[\tilde{X}_1(n\omega)]_{\theta_1} + \tilde{Z}_{12}(n\omega)[\tilde{X}_2(n\omega)]_{\theta_2} + \tilde{Z}_{13}(n\omega)[\tilde{X}_3(n\omega)]_{\theta_3} + \dots + \tilde{Z}_{1m}(n\omega)[\tilde{X}_k(n\omega)]_{\theta_k} \quad (15)$$

Where, \tilde{p}_q and \tilde{X}_r are pressure and volume velocity in the frequency domain.

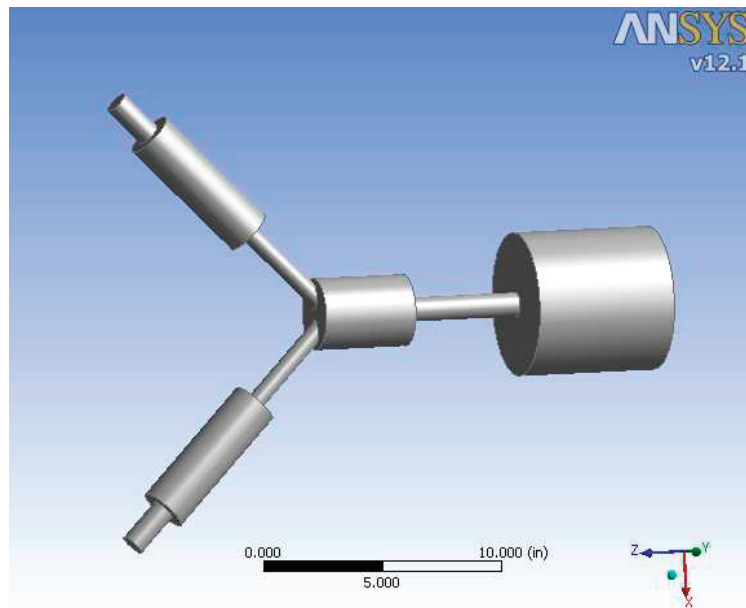

Figure 6: Finite element model of the multiple inputs.

This new FE hybrid technique was used to determine the pressure responses of the model in Fig. 6. The results in Fig. 7 and Fig. 8 show that the pressure response at location P_{L11} and P_{M11} obtained by using FE hybrid approach matches the pressure response obtained by 1D wave equation analytical solution and CFD methods.

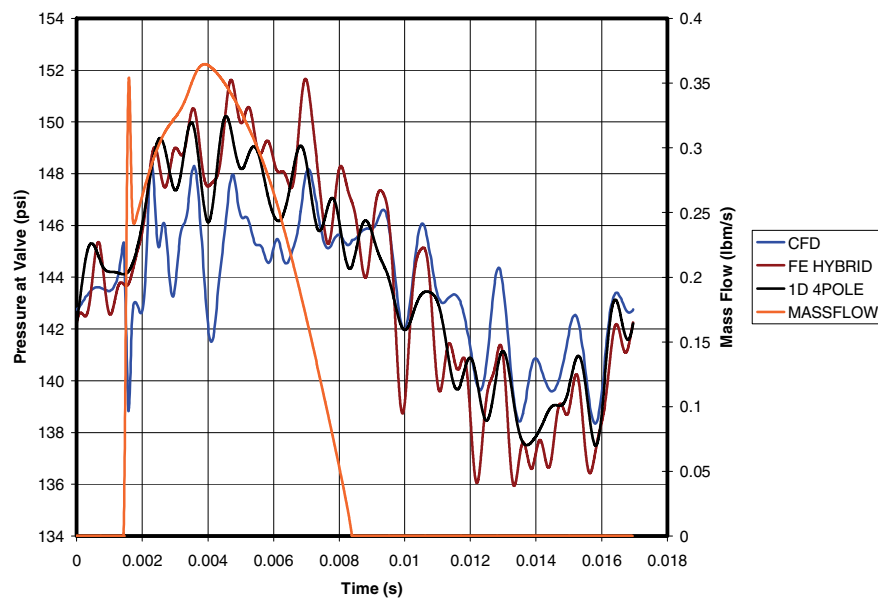

Figure 7: Pressure in cylinder 1 at valve location P_{L11} .

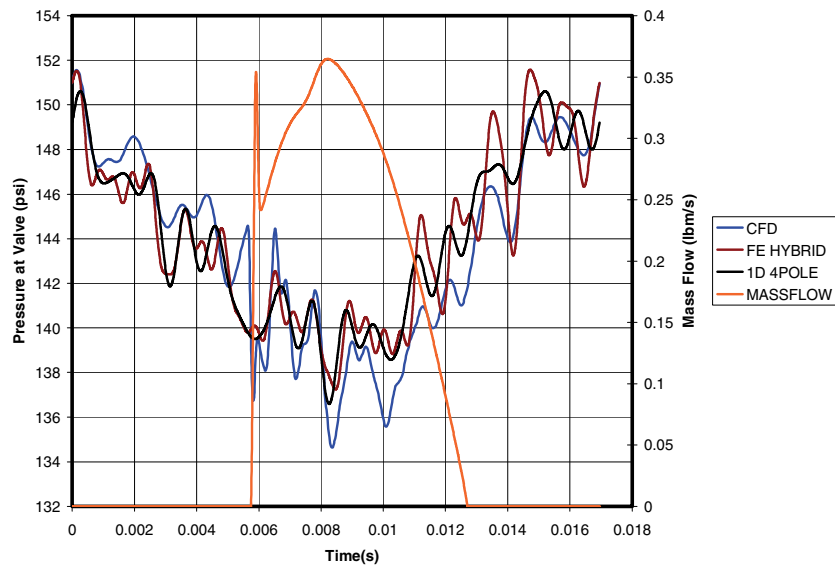

Figure 8: Pressure in cylinder 2 at valve location P_{M11} .

The same hybrid approach of using the pressure response functions can be applied to the more complex suction and discharge manifolds with multiple inputs.

6. CONCLUSIONS

A hybrid approach using the finite element method in combination with an analytical model can be used to calculate the pressure response in the suction or a discharge system. The advantage of using this approach is that the pressure response in an acoustic cavity can be calculated without any geometric simplifications on actual 3D CAD designs. This approach has been used to model a complete intake system including the internal shell cavity. The hybrid approach allows for complex multiple input designs or multiple cylinder compressors. This approach is also more efficient compared to the CFD method, which is computationally quite expensive. The hybrid four pole parameters can also be used inside a compressor simulation model to study the effects of the geometric changes on the pressure response, in the cavity, and performance of the compressor. Because the four poles coefficients are independent of mass flow, modifications to the valve (lift or timing) and cylinder design (stroke or piston diameter) can be done inside a compressor simulation model without having to resolve new four pole parameters. The hybrid approach still needs to follow the linear acoustic constraints of the 1D four pole method. The four pole parameters can also be used to calculate the acoustic transmission loss of the system to help in noise reduction.

REFERENCES

- Kadam, P. H., 2005, Development and Comparison of Analytic, Numerical and Experimental Techniques to formulate Four-Poles Matrices of Three Dimensional Acoustic Systems, *MSc. Thesis*, University of Cincinnati.
- Park, J., 2004, Mathematical Modeling and Simulation of a Multi-Cylinder Automotive Compressor, *PhD Thesis*, Purdue University.
- Singh, R., Soedel, W., 1979, Mathematical Modeling of Multicylinder Compressor Discharge System Interactions, *Journal of Sound and Vibration*, vol. 63, no. 1: p. 125-143.
- Soedel, W., 2006, Sound and Vibrations of Positive Displacement Compressors, *CRC Press*.
- Wu, T. W., Zhang, P., 1998, Boundary Element Analysis of Mufflers with an Improved Methods for Deriving the Four Pole Parameters, *Journal of Sound and Vibration*, vol. 217, no. 4: p. 767-779.