

2016

Analysis of Viscous Slip at the Wall in Gas Flows of R134a and R600a through Metallic Microtubes

Ernane Silva

Federal University of Santa Catarina, Brazil, ernane@polo.ufsc.br

Murilo F. Nicoluzzi

Federal University of Santa Catarina, Brazil, nicoluzzi@polo.ufsc.br

Marcos Rojas-Cardenas

Université Fédérale Toulouse Midi-Pyrénées, France, marcos.rojas@insa-toulouse.fr

Cesar J. Deschamps

Federal University of Santa Catarina, Brazil, deschamps@polo.ufsc.br

Follow this and additional works at: <https://docs.lib.purdue.edu/icec>

Silva, Ernane; Nicoluzzi, Murilo F.; Rojas-Cardenas, Marcos; and Deschamps, Cesar J., "Analysis of Viscous Slip at the Wall in Gas Flows of R134a and R600a through Metallic Microtubes" (2016). *International Compressor Engineering Conference*. Paper 2459. <https://docs.lib.purdue.edu/icec/2459>

This document has been made available through Purdue e-Pubs, a service of the Purdue University Libraries. Please contact epubs@purdue.edu for additional information.

Complete proceedings may be acquired in print and on CD-ROM directly from the Ray W. Herrick Laboratories at <https://engineering.purdue.edu/Herrick/Events/orderlit.html>

Analysis of Viscous Slip at the Wall in Gas Flows of R134a and R600a through Metallic Microtubes

Ernane SILVA¹, Murilo F. NICOLUZZI¹, Marcos ROJAS-CARDENAS², Cesar J. DESCHAMPS^{1*}

¹POLO Research Laboratories for Emerging Technologies in Cooling and Thermophysics
Federal University of Santa Catarina
88040-900, Florianopolis, SC, Brazil
deschamps@polo.ufsc.br

²Institut Clément Ader UMR CNRS 5312
Université de Toulouse, INSA de Toulouse
Toulouse, France
marcos.rojas@insa-toulouse.fr

* Corresponding Author

ABSTRACT

The leakage of gas between the reed valve and the valve seat may significantly affect the efficiency of compressors adopted for household refrigeration. Such leakages are induced by differences of pressure between the compression chamber and the suction/discharge chamber and occur through small gaps in the order of micrometer, formed as a result of surface imperfections. Given the small dimensions of these clearances, a rarefied flow of refrigerant can occur under some operating conditions of the compressor. In this case, non-equilibrium phenomena, such as viscous slip between the fluid and solid boundaries, appear and they cannot be predicted by the classical fluid-mechanics continuum assumptions. The tangential momentum accommodation coefficient (TMAC) is a flow parameter that must be considered in order to correctly describe these rarefied gas flows, characterizing the exchange of momentum between the gas molecules and the surface. Many studies provide the value of TMAC, but usually the results are limited to nitrogen and noble gases for glass and silicon microchannels. The present paper reports measurements of mass flow rates and TMAC values for R134a and R600a through metallic microtubes (stainless steel and copper). The results show that viscous slip can occur even in flows of heavy polyatomic molecules typical of gases used in the refrigeration industry.

1. INTRODUCTION

Gas leakage is a well-known source of inefficiency in positive displacement compressors and can significantly reduce the volumetric and isentropic efficiencies. Such leakages can occur between the valves and valve seats as a result of surface irregularities and misalignment, which are responsible for the incomplete sealing. This can be especially important in oil-free compressors, since the presence of lubricating oil tends to improve sealing. Despite its importance, few studies in the literature have reported this problem. Machu (1990) conducted a theoretical analysis of a double acting cylinder compressor while Silva and Deschamps (2015) developed a numerical model to estimate the leakage in reed valves. Machu (1990) indicated that the tightness of the valve has a great effect on the efficiency in some operating conditions, while Silva and Deschamps (2015) showed that valve leakage may significantly deteriorate the compressor performance even for very small clearances.

Because of its micrometric scale, the gap formed between the valve and valve seat causes the flow to be rarefied under some operating conditions of the compressor (Silva and Deschamps, 2015). In this flow situation, non-continuum effects, such as viscous slip, thermal transpiration, and temperature jump at the wall, are significant and must be taken into account. Different theories are used to describe the flow according to the level of rarefaction, which is measured

by means of the Knudsen number (Kn), defined as the ratio of the mean free path of the gas (λ) and the characteristic dimension of the system (L):

$$Kn = \frac{\lambda}{L} \quad (1)$$

The characteristic dimension of the system (L) can be calculated locally based on the gradients of macroscopic parameters of the flow. However, it is usually assumed to be a constant value, especially in the case of channels with constant cross-section. For microtubes, the characteristic dimension of the system is normally assumed to be the internal diameter (D), as considered in this work. An expression for the mean free path depends on the models considered to describe the molecular interactions between the gas molecules. For simplicity purposes, we adopt the formula proposed by Maxwell (1879):

$$\lambda = \sqrt{\frac{\pi}{2}} \frac{\mu \sqrt{RT}}{P} \quad (2)$$

For values of Kn around 10^{-3} - 10^{-2} , or greater, the flow is considered to be rarefied, invalidating the flow description via the classical continuum hypothesis with the use of no-slip boundary conditions at the walls. Under such circumstances, the interaction of the gas molecules with the channel surfaces plays an important role in order to model properly the physical behavior of the flow. The tangential momentum accommodation coefficient (TMAC) is normally adopted to describe statistically such interactions, and can be understood as the fraction of molecules (α) with diffuse reflection at the walls. Conversely, $1 - \alpha$ represents the fraction of molecules with specular reflection, that is, the fraction of molecules that have the same tangential momentum before and after the collision against the wall. The value of TMAC may vary with the chemical composition of the gas, surface material, roughness and level of contamination, as well as gas temperature (Agrawal and Prabhu, 2008).

The TMAC has already been experimentally determined for a variety of gases and materials. Nevertheless, the majority of the experiments have been performed with nitrogen and noble gases flowing through silicon and/or silica microchannels or microtubes (Maurer *et al.*, 2003; Colin *et al.*, 2004; Graur *et al.*, 2009). Some exceptions are the works of Arkilic *et al.* (2001), Hadj Nacer *et al.* (2014), Yamaguchi *et al.* (2011, 2012), Szalmas *et al.* (2010), and Pitakarnnop *et al.* (2010), which have also considered flows of carbon dioxide, oxygen and gas mixtures. To our knowledge, the only efforts to test metallic surfaces were undertaken by Hadj Nacer *et al.* (2011), who covered the internal surfaces of the microchannel with a thin gold coat, and by Yamaguchi *et al.* (2012) and Hadj Nacer *et al.* (2014), who studied rarefied gas flows in commercially available stainless microtubes. More recently, Silva *et al.* (2016) presented experimental results of TMAC for the refrigerant gases R134a and R600a flowing through a commercially available stainless steel microtube. In this paper, the analysis has been extended to different metallic materials, such as stainless steel and copper. The mass flow rate of R134a and R600a were measured by means of the dynamic constant-volume technique and compared to analytical expressions in the range of Kn up to 0.3 in order to extract the corresponding values of TMAC. Although the geometry of the microtubes does not correspond to the geometry of the gap between the valve and valve seat, these experiments allow the determination of the TMAC, which is independent of the flow geometry and a necessary parameter in models adopted to predict valve leakage.

2. EXPERIMENTAL APPARATUS AND METHODOLOGY

2.1 Experimental Apparatus

The measurement of mass flow rates of gases through single microtubes is usually a difficult task given the small magnitudes involved. Different methods have been employed, with the direct measurement using flow meters being the simplest one (Jang and Wereley, 2004). Since this method is usually limited to mass flow rates higher than 10^{-8} kg/s (Ewart *et al.*, 2006), the constant-volume (Arkilic *et al.*, 1997; Ewart *et al.*, 2006; Pitakarnnop *et al.*, 2010) and the drop tracking methods (Colin *et al.*, 2004; Ewart *et al.*, 2006), which are indirect measurement techniques, have become the most commonly used techniques for measuring small mass flow rates of gases. In the present study, we adopted a dynamic measurement technique based on the constant-volume method, which was an alternative version of the well-known constant-volume proposed by Rojas-Cárdenas *et al.* (2011) for the measurement of mass flow rates induced by temperature gradients. Silva *et al.* (2016) applied recently the same technique for the case of pressure-driven isothermal flows. The experimental setup (Figure 1) consists of a test section with two rigid reservoirs (R1 and

R2) equipped with pressure (PT1 and PT2) and temperature (TT1 and TT2) transducers. These reservoirs are connected by the micro-device to be analyzed. The inlet and outlet valves (A and B) are used to isolate the test section from the other components of the system when necessary.

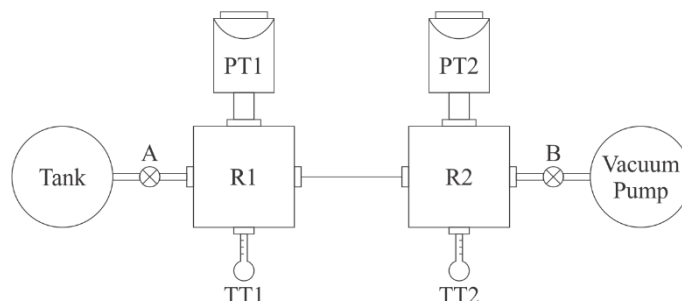

Figure 1: Experimental setup.

Capacitance diaphragm gauges with full scales of 133Pa or 1333Pa and accuracy 0.2% of reading were used to measure pressure in the upstream and downstream reservoirs, while T-type thermocouples were used for temperature measurements. The experiments were conducted through a stainless steel microtube ($D = 438.6 \pm 4.5 \mu\text{m}$, $L = 92.22 \pm 0.01 \text{mm}$) and a copper microtube ($D = 444.17 \pm 4.5 \mu\text{m}$, $L = 92.44 \pm 0.01 \text{mm}$).

The volumes of the upstream (R1) and downstream (R2) reservoirs were measured to be $181.1 \pm 0.9 \text{ ml}$ and $28.5 \pm 0.8 \text{ ml}$, respectively. A tank with the gas to be analyzed was connected to the upstream reservoir (R1). Commercially available R134a and R600a gases were used in the experiments and their viscosities were obtained from the correlations developed by Huber *et al.* (2003) and Younglove and Ely (1987), respectively. The properties of the gases are provided in Table 1.

Table 1: Properties of the gases R134a and R600a.

Gas	$\mu \times 10^{-5} [\text{Pa s}]^*$	$R [\text{J kg}^{-1} \text{K}^{-1}]$
R134a	1.181	81.50
R600a	0.7415	143.06

* at 297.15K

Even though the microtubes used in the experiments have small diameters, the dimensions of the gaps between the valve and valve seat are much smaller, on the order of micrometer (Rezende *et al.*, 2016). Therefore, with the purpose of reproducing the rarefied flow conditions that occur in the flow between the valve and the valve seat of compressors, it was necessary to lower the pressure inside the test section by means of a vacuum pump connected to the reservoir downstream of the micro-device (R2), obtaining a similarity between the flows in terms of the Knudsen number (Kn).

Tests were carried out by setting a uniform pressure in the test section and monitoring it for long periods, much longer than the duration of a single experiment, in order to assure that the test-section was leakage-free. In all cases, the difference between the highest and lowest pressures measured during a typical test of two hours did not exceed the uncertainty of the pressure sensors, meaning that air from the outside ambient was not able to leak towards the experimental test-section, at least in a measurable proportion.

2.2 Mass Flow Rate Measurements

The dynamic constant-volume technique consists in tracking the pressure variation with time inside the reservoirs R1 and R2 when a pressure difference is established between both ends of the micro-device. In this case, both valves A and B must be closed and the volumes of the reservoirs must be known. Thus, the variations of pressure can be associated with the mass flow rate of gas flowing through the micro-device by assuming a quasi-steady process.

By using the equation of state for an ideal gas, the mass flow rate through the micro-device, \dot{M} , can be related to the pressure variation with time in any of the two reservoirs (R1 or R2) as

$$\dot{M} = \frac{dM_i}{dt} = \frac{V_i}{RT_i} \frac{dP_i}{dt} (1 - \varepsilon) \quad , i = 1, 2 \quad (3)$$

where M_i is the mass of gas in the reservoir, V_i is the volume of the reservoir, R is the specific gas constant, t is the time, and P_i and T_i are, respectively, the pressure and temperature of the gas in the reservoir. The term

$$\varepsilon = \left(\frac{dT_i}{dt} / T_i \right) / \left(\frac{dP_i}{dt} / P_i \right) \quad (4)$$

takes under account the variation of temperature in relation to the variation of pressure and gives an indication of how closely the experiment follows the isothermal condition. For all experimental cases considered it was assured that $\varepsilon \leq 0.01$ and hence the mass flow rate was calculated based solely on the pressure variation with time (Equation (3), with $\varepsilon = 0$), considering a maximum relative standard uncertainty of 1% related to the temperature variation.

Each experimental campaign was performed via the following steps: a) the entire system was pumped down for long periods in order to assure that no residual gases were left, after which valves A and B were closed (Figure 1); b) valve A was opened and gas from the high pressure tank was allowed to enter the system until a desired upstream pressure was achieved, when then valve A was closed again; c) valve B was opened in order to release some gas from reservoir R2 into the vacuum pump, creating thus a pressure difference between the two tanks; d) valve B was closed and the experiment initiated with the pressure relaxation process taking place in both reservoirs until a final equilibrium pressure was reached in the entire test section (Figure 2a). Steps from “b” to “d” were repeated for different initial pressures until all the rarefaction range of interest was analyzed.

The dynamic constant-volume technique relies on the assumption that the pressure variation with time inside the reservoirs can be described by a fitting function $P_i(t)$. Then, the mass flow rate is calculated from the time derivative of this function (Equation (3)). The main advantage of the dynamic technique in respect to the classical constant-volume method is that a large data set is obtained from a single experiment. In fact, during a single experiment, a wide range of rarefaction conditions can be investigated, since both the pressures in the upstream and downstream reservoirs vary with time (Figure 2b). The rarefaction condition is measured by means of the average Knudsen number (Kn_m), which is calculated from Equation (1) based on the average pressure along the tube given by $P_m = (P_1 + P_2)/2$.

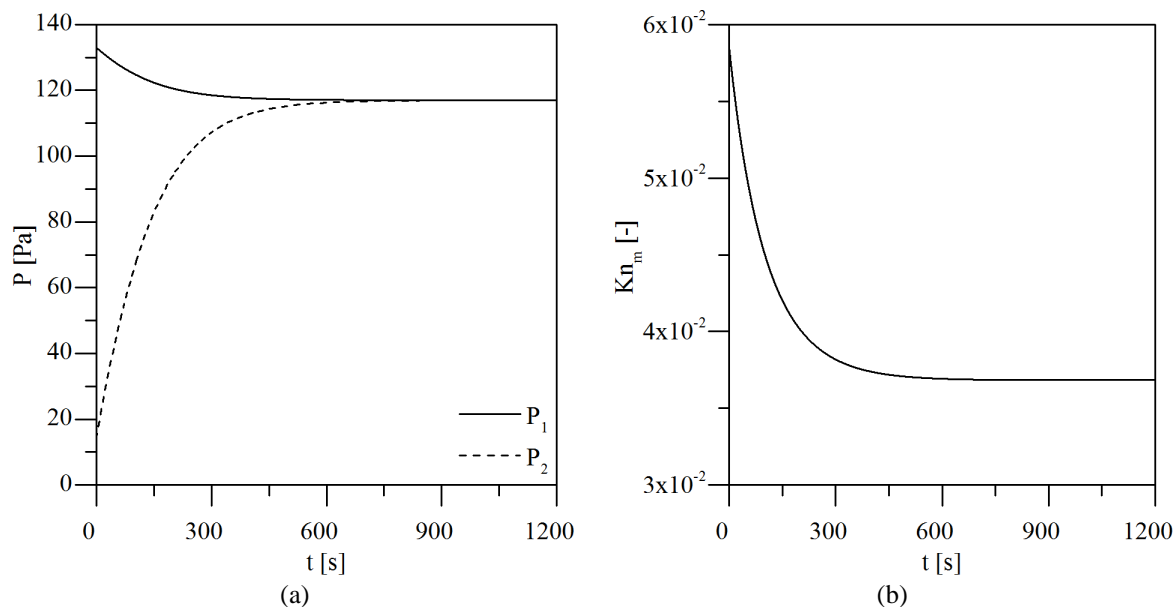

Figure 2: Data from a single experiment with R600a in a copper microtube: (a) variation of pressure in the reservoirs and (b) variation of Kn_m .

2.3 Determination of TMAC

For slightly rarefied gas flows ($Kn \leq 0.1$), the mass flow rate of gas through a tube of diameter D can be obtained directly from the solution of the Navier-Stokes equation provided that the boundary conditions are modified to account for velocity slip at the wall. Several authors (Maurer *et al.*, 2003; Colin *et al.*, 2004; Ewart *et al.*, 2006; Yamaguchi *et al.*, 2011) have proposed the use of second-order slip boundary conditions to extend the validity of the continuum equations for moderately rarefied gas flows ($Kn \leq 0.3$). In this case, the slip velocity reads as follows:

$$u_s = \pm A_1 \lambda \left(\frac{\partial u}{\partial r} \right)_w - A_2 \lambda^2 \left[\frac{1}{r} \left(\frac{\partial}{\partial r} r \frac{\partial u}{\partial r} \right) \right]_w \quad (5)$$

where A_1 and A_2 , according to the molecular collision model considered herein, are defined as

$$A_1 = \frac{2}{\sqrt{\pi}} \sigma_P \quad , \quad A_2 = \frac{4}{\pi} \sigma_{2P} \quad (6)$$

In this equation σ_P and σ_{2P} stand for the first and second viscous slip coefficients, respectively. The TMAC (α) can be related to σ_P following the Maxwellian model that describes the gas/surface interaction, i.e.:

$$\sigma_P = \frac{\sqrt{\pi} 2 - \alpha}{2} \frac{\alpha}{\alpha} \quad (7)$$

Taking into account the velocity slip at the wall (Equation (5)), an analytical solution for the mass flow rate can be easily obtained for the case of a long tube

$$\dot{M} = \frac{\pi D^4 \Delta P P_m}{128 \mu R T L} \left(1 + 8 A_1 K n_m + 32 A_2 \frac{P_m}{\Delta P} \ln \Pi K n_m^2 \right) \quad (8)$$

where $\Delta P = P_1 - P_2$ is the pressure difference between inlet and outlet reservoirs, $\Pi = P_1/P_2$ is the pressure ratio, $P_m = (P_1 + P_2)/2$ is the mean pressure, and L is the length of the tube. An expression for the non-dimensional mass flow rate, S , is obtained by dividing Equation (8) by the Poiseuille analytical solution for the hydrodynamic regime (i.e., $Kn_m \rightarrow 0$):

$$S = \frac{128 \mu R T L}{\pi D^4 \Delta P P_m} \dot{M} = 1 + 8 A_1 K n_m + 32 A_2 \frac{P_m}{\Delta P} \ln \Pi K n_m^2 \quad (9)$$

The coefficients of Equation (9) can be obtained by curve fitting of the experimental data of mass flow rate, as described by Maurer *et al.* (2003), with the slip coefficients and the TMAC being obtained from Equations (6) and (7), respectively.

3. RESULTS

Four series of experiments were conducted to cover a wide range of flow rarefaction for the gases and materials considered. In all experiments the pressure variation with time in each reservoir was fitted and the mass flow rate was obtained from Equation (3). The mass flow rates extracted from the first 400s of pressure variation presented in Figure 2 can be seen in Figure 3a. In this case, both the results obtained from the variations of pressure in the upstream and downstream reservoirs are presented and show an excellent agreement, within the uncertainty range, proving that the technique is solid and accurate. The relative uncertainty in the mass flow rate measurements obtained from the downstream reservoir is estimated to be 3% and this margin of uncertainty is represented in the graph by the thinner solid lines. Since the downstream reservoir (R2) has a smaller volume, the variations of pressure are higher in respect to the variations of temperature, and the isothermal condition is more properly satisfied (Figure 3b). For this reason, the mass flow rate obtained from the pressure measurement in the downstream reservoir could be considered to be more accurate and were used to extract the TMAC.

The non-dimensional mass flow rate, S , given by Equation (9) and presented as a function of Kn_m in Figure 4, can be regarded as a measure of the rarefaction effect. The higher is the value of S the higher is the influence of rarefaction on the mass flow rate. When S equals to unity no rarefaction effect is observed. Figure 4 shows a slightly higher velocity slip for the flows in the microtube of copper, even though the differences are inside the uncertainty range. It is also possible to note in Figures 4b and 4d that rarefaction increases the mass flow rate by approximately 10% ($S = 1.1$) in both microtubes when $Kn_m = 10^{-2}$. This mass flow rate is further increased with Kn_m , reaching almost 50% ($S = 1.5$) when $Kn_m = 0.05$. Values of Kn_m in this range were predicted by Silva and Deschamps (2015) for a gap of $0.25\mu\text{m}$ between the valve and valve seat. Recent results from Rezende *et al.* (2016) have shown that gaps on this order of dimension are likely to be found in compressor valves and justify the consideration of rarefaction effects in the modeling of leakage.

Results of TMAC extracted from the curve fittings of the non-dimensional mass flow rate shown in Figure 4 are presented in Table 2 together with the respective coefficients of determination. In all cases, coefficients of determination were higher than 0.999, justifying the adoption of a second-order slip boundary condition. An incomplete accommodation ($\alpha < 1$) was observed for all cases and smaller TMAC (α) values were found for the copper in relation to the stainless steel microtube, even though the differences in the mass flow rate measurements are within the uncertainty range.

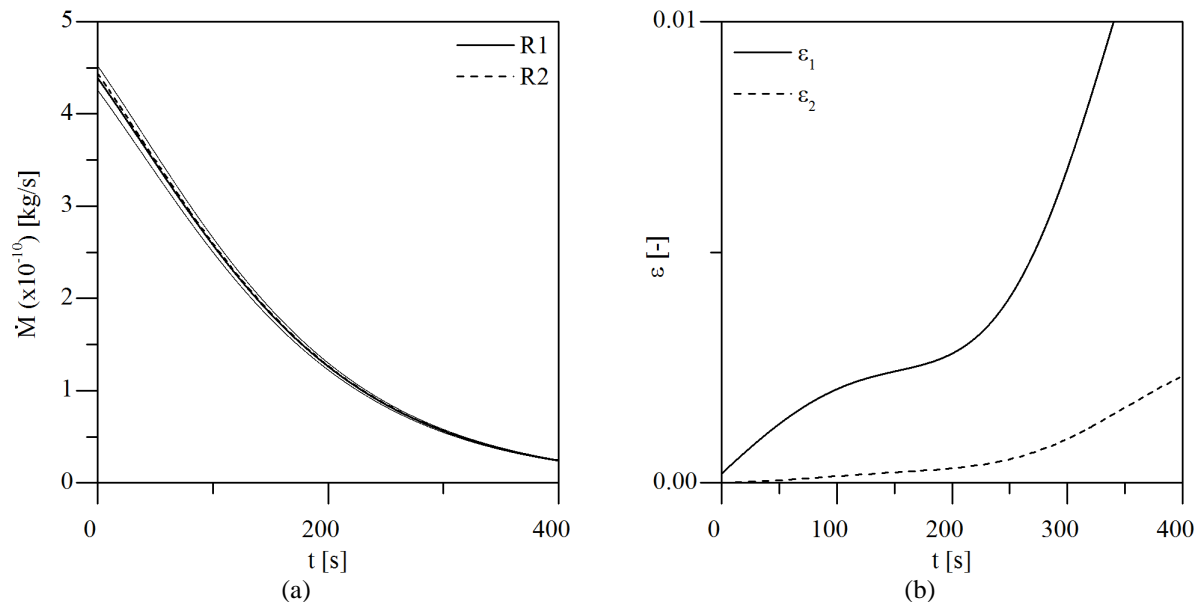

Figure 3: Data extracted from a single experiment with R600a in a copper microtube: (a) variation of the mass flow rates through the microtube and (b) variation of ϵ .

Table 2: TMAC and coefficient of determination of the curve fitting of S .

Microtube	Gas	α	R^2
Stainless Steel	R134a	0.956	0.999
	R600a	0.974	0.999
Copper	R134a	0.917	1.000
	R600a	0.938	1.000

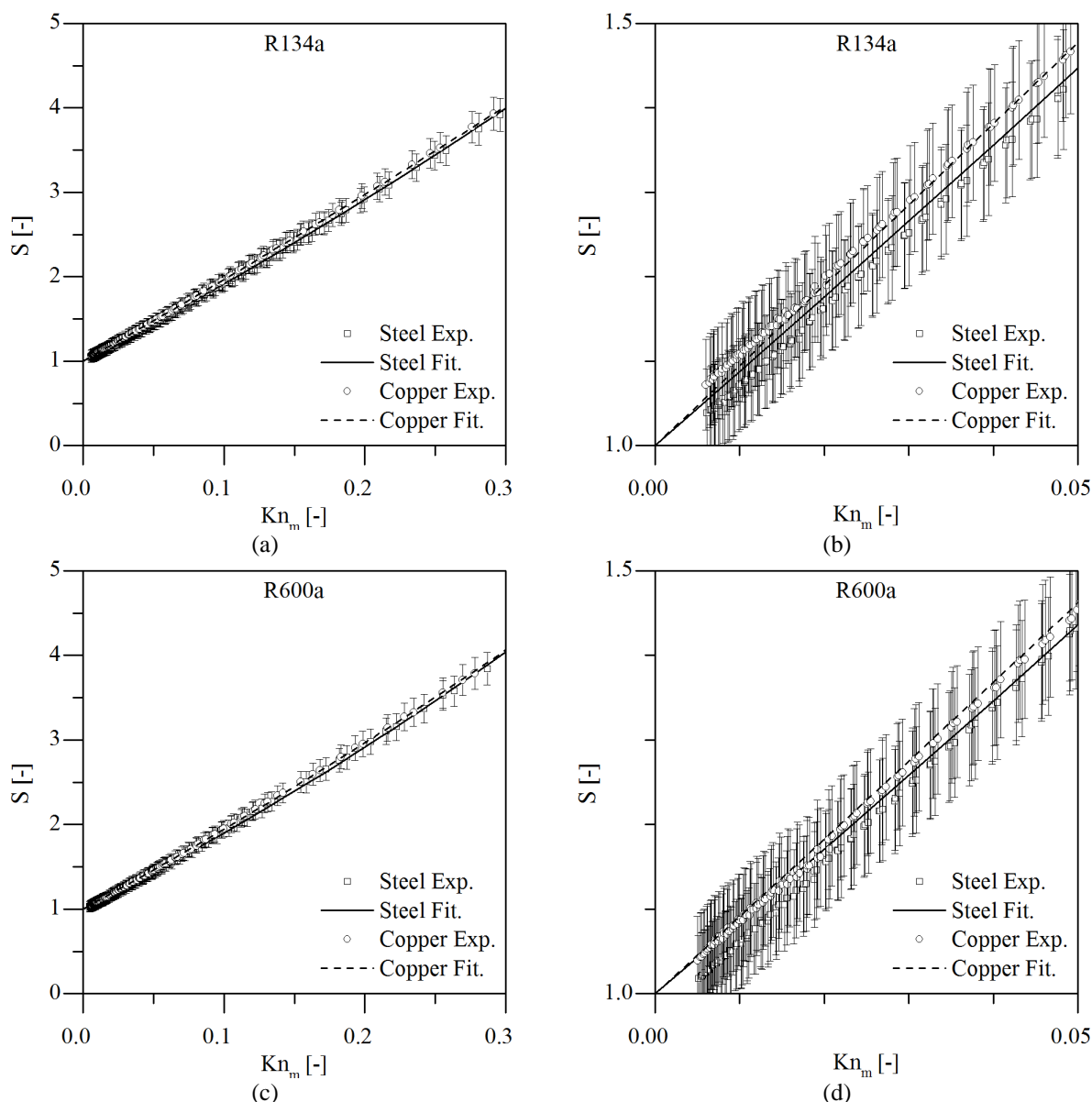

Figure 4: Non-dimensional mass flow rate as a function of Kn_m : (a)-(b) R134a and (c)-(d) R600a.

4. CONCLUSIONS

This paper reported measurements of mass flow rate of rarefied gases through metallic microtubes made of stainless steel and copper, carried out with the dynamic constant-volume method. Flows of gases commonly employed in the refrigeration industry, namely R134a and R600a, were considered and it was shown that rarefaction effects can occur even in such gases of complex polyatomic molecules. Tangential momentum accommodation coefficients (TMAC) were found in the range of 0.917 to 0.974 for the two gases and microtubes investigated, confirming the existence of an incomplete accommodation of the molecules at the walls ($\alpha < 1$). Our results also indicated that the metallic material of the microtube does not have great influence on TMAC when there is no special surface treatment, usually referred to as engineering surfaces, even though the results suggest a higher velocity slip in the copper microtube. Future investigations will be focused on the effect of the surface roughness on the TMAC. It is expected that the roughness of the surface plays a more significant role than the surface material when rough surfaces are considered. Probably the surface material will be more relevant for atomically smooth surfaces, but such a surface finishing is not found in compressors.

NOMENCLATURE

A_1	1 st coefficient of the velocity slip boundary condition	(-)
A_2	2 nd coefficient of the velocity slip boundary condition	(-)
D	diameter	(m)
Kn	Knudsen number	(-)
L	length	(m)
M, \dot{M}	mass, mass flow rate	(kg, kg s ⁻¹)
$P, \Delta P$	pressure, difference of pressure	(Pa, Pa)
r	radial coordinate	(m)
R	specific gas constant	(J kg ⁻¹ K ⁻¹)
S	non-dimensional mass flow rate	(-)
t	time	(s)
T	temperature	(K)
u	velocity	(m s ⁻¹)
u_s	slip velocity	(m s ⁻¹)
V	volume	(m ³)
ε	relative variation of temperature	(-)
λ	mean free path	(m)
μ	dynamic viscosity	(Pa s)
Π	pressure ratio	(-)
σ_p	1 st order slip coefficient	(-)
σ_{2p}	2 nd order slip coefficient	(-)

Subscript

i	generic reservoir
m	mean
w	wall

REFERENCES

- Agrawal, A., Prabhu, S. V. (2008). Survey on the measurement of tangential momentum accommodation coefficient. *J. Vac. Sci. Technol. A* 26(4), 634-645.
- Arkilic, E. B., Schmidt, M. A., Breuer, K. S. (1997). Gaseous slip flow in long microchannels. *J. Microelectromech. Syst.* 6, 167-178.
- Arkilic, E. B., Breuer, K. S., Schmidt, M. A. (2001). Mass flow and tangential momentum accommodation in silicon micromachined channels. *J. Fluid Mech.* 437, 29-43.
- Colin, S., Lalonde, P., Caen, R. (2004). Validation of a second-order slip flow model in rectangular microchannels. *Heat Transfer Eng.* 25, 23-30.
- Ewart, T., Perrier, P., Graur, I., Méolans, J. G. (2006). Mass flow rate measurements in gas micro flows. *Exp. Fluids* 41, 487-498.
- Graur, I. A., Perrier, P., Ghazlani, W., Méolans, J. G. (2009). Measurements of tangential momentum accommodation coefficient for various gases in plane microchannel. *Phys. Fluids* 21, 102004.
- Hadj Nacer, M., Graur, I., Perrier, P. (2011). Mass flow measurement through rectangular microchannel from hydrodynamic to near free molecular regimes. *Houille Blanche* 4, 49-54.
- Hadj Nacer, M., Graur, I., Perrier, P., Méolans, J. G., Wuest, M. (2014). Gas flow through microtubes with different internal surface coatings. *J. Vac. Sci. Technol., A* 32, 021601.
- Huber, M. L., Laesecke, A., Perkins, R. A. (2003). Model for the viscosity and thermal conductivity of refrigerants, including a new correlation for the viscosity of R134a. *Ind. Eng. Chem. Res.* 42, 3163-3178.
- Jang, J., Wereley, S. T. (2004). Pressure distributions of gaseous slip flow in straight and uniform rectangular microchannels. *Microfluid Nanofluidics* 1, 41-51.
- Machu, E. (1990). How leakages in valves can influence the volumetric and isentropic efficiencies of reciprocating compressors, *Proceedings of the International Compressor Engineering Conference* (482-494). West Lafayette, USA.

- Maurer, J., Tabeling, P., Joseph, P., Willaime, H. (2003). Second-order slip laws in microchannels for helium and nitrogen. *Phys. Fluids* 15, 2613-2621.
- Maxwell, J. C. (1879). On stresses in rarefied gases arising from inequalities of temperature. *Philosophical Transactions of the Royal Society of London* 170, 231-256.
- Pitakarnnop, J., Varoutis, S., Valougeorgis, D., Geoffroy, S., Baldas, L., Colin, S. (2010). A novel experimental setup for gas microflows. *Microfluid Nanofluidics* 8, 57-72.
- Rezende G. C., Silva, E., Deschamps, C. J. (2016). A hybrid experimental-numerical procedure to estimate the leakage gap in compressor valves, *Proceedings of the International Compressor Engineering Conference* (1-10). West Lafayette, USA.
- Rojas-Cárdenas, M., Graur, I., Perrier, P., Meolans, J. G. (2011). Thermal transpiration flow: a circular cross-section microtube submitted to a temperature gradient. *Phys. Fluids* 23, 031702.
- Silva, L. R., Deschamps, C. J. (2015). Modeling of gas leakage through compressor valves. *Int. J. Refrigeration* 53, 195-205.
- Silva, E., Rojas-Cárdenas, M., Deschamps, C. J. (2016). Experimental analysis of velocity slip at the wall for gas flows of nitrogen, R134a, and R600a through a metallic microtube. *Int. J. Refrigeration*, In Press.
- Szalmas, L., Pitakarnnop, J., Geoffroy, S., Colin, S., Valougeorgis, D. (2010). Comparative study between computational and experimental results for binary rarefied gas flows through long microchannels. *Microfluid Nanofluidics* 9, 1103-1114.
- Yamaguchi, H., Hanawa, T., Yamamoto, O., Matsuda, Y., Egami, Y., Niimi, T. (2011). Experimental measurement on tangential momentum accommodation coefficient in a single microtube. *Microfluid Nanofluidics* 11, 57-64.
- Yamaguchi, H., Matsuda, Y., Niimi, T. (2012). Tangential momentum accommodation coefficient measurements for various materials and gas species. *J Phys.: Conf. Ser.* 362, 012035.
- Younglove, B. A., Ely, J. F. (1987). Thermophysical properties of fluids. II. Methane, ethane, propane, isobutane and normal butane. *J. Phys. Chem. Ref. Data* 16, 577-798.

ACKNOWLEDGEMENT

The present work was developed with the support of CNPq, National Council for Scientific and Technological Development – Brazil, and is part of a technical-scientific cooperation program between the Federal University of Santa Catarina and EMBRACO. The authors would like to express their gratitude to the invaluable support of the Center of Reference in Innovative Technologies (CERTI) in providing the measurements of the microtube diameters. The authors also thank EMBRAP II Unit Polo/UFSC and CAPES (Coordination for the Improvement of High Level Personnel) for the financial support.