

2018

# Dynamic Performance of a Mechanical Vapor Compression (MVC) Desalination System

Sergio Morales Ruiz  
*CTTC UPC, Spain, sergio@cttc.upc.edu*

Jesús Castro  
*CTTC UPC, Spain, jesus@cttc.upc.edu*

Jordi Rovira  
*quim@cttc.upc.edu*

Carles Oliet  
*Centre Tecnològic de Transferència de Calor (CTTC), Universitat Politècnica de Catalunya (UPC), carles@cttc.upc.edu*

Assensi Oliva  
*Heat and Mass Transfer Technological Center – Universitat Politècnica de Catalunya, Terrassa (Barcelona), Spain, oliva@cttc.upc.edu*

Follow this and additional works at: <https://docs.lib.purdue.edu/iracc>

---

Morales Ruiz, Sergio; Castro, Jesús; Rovira, Jordi; Oliet, Carles; and Oliva, Assensi, "Dynamic Performance of a Mechanical Vapor Compression (MVC) Desalination System" (2018). *International Refrigeration and Air Conditioning Conference*. Paper 1960. <https://docs.lib.purdue.edu/iracc/1960>

This document has been made available through Purdue e-Pubs, a service of the Purdue University Libraries. Please contact [epubs@purdue.edu](mailto:epubs@purdue.edu) for additional information.

Complete proceedings may be acquired in print and on CD-ROM directly from the Ray W. Herrick Laboratories at <https://engineering.purdue.edu/Herrick/Events/orderlit.html>

## Dynamic Performance of a Mechanical Vapor Compression (MVC) Desalination System

Sergio MORALES-RUIZ<sup>1\*</sup>, Jesús CASTRO<sup>1</sup>, Joaquim RIGOLA<sup>1</sup>, Carles OLIET, Assensi OLIVA<sup>1</sup>

<sup>1</sup>Universitat Politècnica de Catalunya – Barcelona Tech (UPC),  
Heat and Mass Transfer Technological Center (CTTC), Terrassa, (Barcelona), Spain  
(+34 937398192, +34 937398920, www.cttc.upc.edu)

\* cttc@cttc.upc.edu

### ABSTRACT

The present paper presents a numerical model to analyze the thermal and fluid dynamic behavior of a mechanical vapor compression MVC desalination system. The MVC desalination is a method to obtain distilled water using the evaporation and condensation processes at the same time, both occur at low pressure (values lower than atmospheric pressure). This method requires a compression work to increase the saturation temperature of the vapor mass flow obtained in the evaporator, which is used to feed the condenser. Then, the compressed vapor is condensed, and its latent heat is transferred to the feed seawater.

The numerical modeling is applied to analyze the thermal and fluid dynamic behavior of a MVC desalination system, using renewable energy source (solar energy) to supply the electric requirements of the system. The electrical energy is used to feed the mechanical compressor, a heater, a group of pumps and the control panel of the system.

The numerical model has been validated using experimental data obtained from the technical literature, presenting a good agreement. The performance system analysis has been carried out considering the variability of renewable sources, while the influence of the boundary conditions on the execution of the unit along the time is also analyzed, showing the capabilities of the present model.

### 1. INTRODUCTION

The MVC desalination is used at low and medium scale in comparison with other techniques such as multistage flash desalination (MSF) or reverse osmosis (RO). The MVC desalination unit studied in this paper uses renewable energy to supply the electricity required by the different devices that make up the unit. The reason to use renewable energy is that the MVC desalination system has been thought to work in remote places, where an electric grid is not available. Consequently, the system is obliged to work with a variable power supply. This variability should be well defined to avoid damage and establish secure partial working operation of the MVC desalination system. The transient and steady-state behaviors of the desalination system are evaluated taking into account the variability of the renewable energy sources, where both solar and wind energy are feasible.

The MVC desalination method is an evaporation and condensation process that occurs at low pressure, which requires a compression work to increase the saturation temperature of the vapor. The trend is to use low evaporation temperatures (between 50 to 70°C) to reduce the risk of corrosion and scale deposition (El-Khatib 2004). The compressed vapor is condensed, and its latent heat is transferred to the feed seawater. The applicability of MVC desalination systems in remote places where there is not possible a connection to an electric grid depends on the use of renewable energy sources. However, the renewable energy means variability in the power given. This variability should be well defined to avoid damage and establish secure partial working operation of the desalination system. The MVC desalination is used at low and medium scale in comparison with other techniques such as multistage flash desalination (MSF) or reverse osmosis (RO) (Ettouney, 2006).

The MVC desalination system is divided into three different subsystems, following the strategy proposed by Mazini (2014). The first subsystem is the evaporator and condenser, in which the evaporation and distillation processes are performed. The second is the vacuum and deaeration subsystem, where the low pressure is achieved, and non-condensed gas is stripped. The last subsystem is the mechanical compressor, which is modeled to know its energetic requirement in function of the desalination performance and the climatic conditions. The mathematical formulation of the evaporator/condenser and vacuum subsystem is based on mass, energy and salt balance conservation equations. Compressor model is based on the root blower laws, in which the volumetric flow, velocity, power and the displacement by revolution values are related.

The group of equations is solved by means of the in-house object-oriented tool called NEST, which is capable of linking and solving different elements that making up a system (Damle, et. al., 2011). The MVC desalination system presented in this paper has different components: an evaporator/condenser, a compressor, a deaerator, two heat exchangers and a group of pumps. Although in this numerical platform each component is an object, the whole system resolution is carried out iteratively for solving all its components and transferring the appropriated information between them.

The numerical model has been validated using experimental data obtained from the technical literature (Namine et al. 2014). After that, a virtual test has been carried out, in which the relation between the variability of the renewable energy sources and the capacity of the desalination system (distilled water production) has been evaluated.

## 2. DYNAMIC MODELING

The desalination system has been divided into four different subsystems, following the strategy proposed by Bodalal (2010) and Mazini (2014). The first subsystem is the evaporator and condenser, in which the evaporation and distillation processes are performed. The second is the vacuum and deaeration subsystem, where the low pressure is achieved and non-condensed gas (Oxygen) is stripped. The third subsystem is the mechanical compressor, which is modeled to know its energetic requirement in function of the desalination performance and the climatic conditions. The last subsystem is the heat exchangers, which preconditioning the feed seawater flow temperature, taking advantage of the heat contained in the distilled water and brine flows at the outlet of the evaporator/condenser.

The evaporator and condenser subsystem is modeled describing it as a brine block, vapor space block, and a tube bundle. Figure 1 depicts a schematic representation of these blocks, together with the others subsystems. The receiver subsystem is modeled assuming that there are a liquid block and a vapor space block, depicted in Figure 2. The compressor is modeled following the mechanical model of a rotatory lobe compressor (blower), which uses the geometric configuration and the relation between velocity (rpm) and the displacement by revolution (cfr) of the compressor.

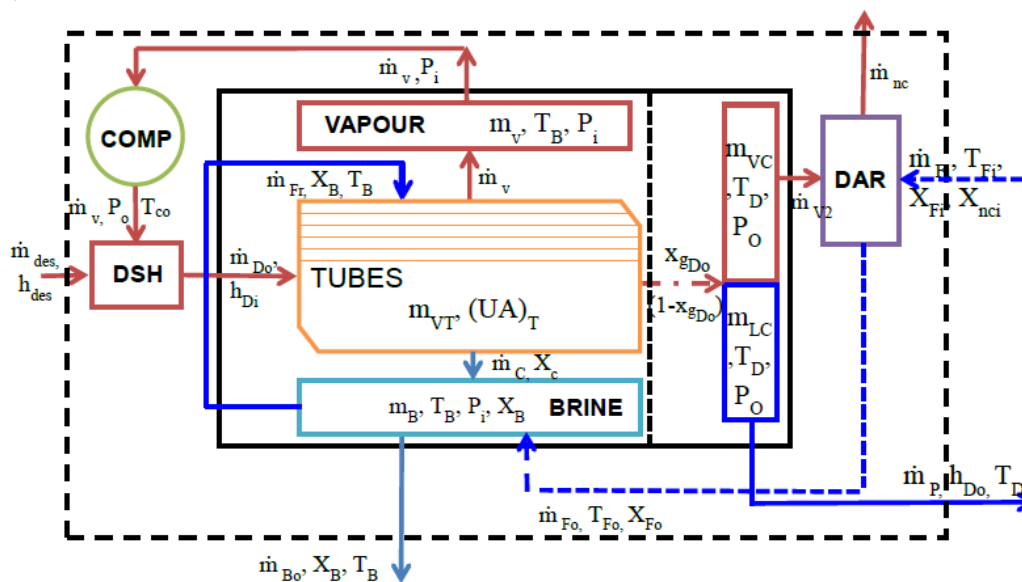

**Figure 1:** Schematic representation of the MVC desalination system and evaporator/condenser subsystems

## 2.1 Mathematical formulation

The mathematical formulation of the evaporator/condenser subsystem is based on mass, and energy balance conservation equations. In the brine volume, mass, energy and concentration equations are solved:

$$\frac{dm_B}{dt} + \dot{m}_{Bo} + \dot{m}_{Fr} - \dot{m}_{Fo} - \dot{m}_C = 0 \quad (1)$$

$$\frac{dm_B u_B}{dt} + \dot{m}_{Bo} h_B + \dot{m}_{Fr} h_B - \dot{m}_{Fo} h_{Fo} - \dot{m}_C h_B = 0 \quad (2)$$

$$\frac{dm_B X_B}{dt} + \dot{m}_{Bo} X_B + \dot{m}_{Fr} X_B - \dot{m}_{Fo} X_{Fo} - \dot{m}_C X_C = 0 \quad (3)$$

Mass density and Energy conservation into the tubes, considering  $\dot{Q}_e = (UA)_T(T_D - T_B)$ :

$$m_{VT} = \rho_D V_{cond} \quad (4)$$

$$\frac{dm_{VT} u_T}{dt} + \dot{m}_{Do}(h_{Do} - h_{Di}) = -\dot{Q}_e \quad (5)$$

State equation and, Mass, Energy and concentration conservation around the tubes:

$$m_V = p_i V_V M / (RT_B) \quad (6)$$

$$\dot{m}_{Fr} - \dot{m}_C - \dot{m}_V = 0 \quad (7)$$

$$\dot{m}_v(\Delta h_{fg}) = \dot{Q}_e \quad (8)$$

$$\dot{m}_C X_C - \dot{m}_{Fr} X_B = 0 \quad (9)$$

Volume Relation into the evaporator/condenser

$$V_T = V_B + V_V = \frac{m_B}{\rho_B} + \frac{m_V}{\rho_V} \quad (10)$$

Mass and Energy balance in the de-super-heating

$$\dot{m}_{Do} = \dot{m}_V + \dot{m}_{Des} \quad (11)$$

$$\dot{m}_{Des} = \dot{m}_V \frac{(h_s - h_{Di})}{h_{Di} - c_{pdes}(T_{des} - T_{ref})} \quad (12)$$

State equation and Mass conservation in the distillate receiver

$$m_{VC} = \frac{p_o V_{VC} M}{RT_{VC}} \quad (13)$$

$$\frac{dm_{VC}}{dt} + \dot{m}_{v2} - x_{gDo} \dot{m}_{Do} = 0 \quad (14)$$

$$\frac{dm_{LC}}{dt} + \dot{m}_P - (1 - x_{gDo}) \dot{m}_{Do} = 0 \quad (15)$$

Volume Relation in the distillate receiver

$$V_{TC} = V_{LC} + V_{VC} = \frac{m_{LC}}{\rho_{LC}} + \frac{m_{VC}}{\rho_{VC}} \quad (16)$$

## 2.2 Numerical resolution

The group of equations is solved using the in-house object-oriented tool called NEST, which is capable of linking and solving different elements that making up a system (Damle, et. al., 2011; Farnós, et. al., 2017). The MVC desalination system presented in this paper has different components: an evaporator/condenser, a compressor, a deaerator, two heat exchangers and a group of pumps. Although in this numerical platform each component is an object, the whole system resolution is carried out iteratively by solving all its components and transferring the appropriated information between them. Table 1 shows the inlet and outlet variables analysed in this system.

A dynamic model based on mass, energy and salt balances and applied to internal components of the MVC desalination system has been implemented to analyze the transient behavior of the MVC desalination system, which uses renewable source energy.

**Table 1:** Variables information transfer between equations system.

	Inlet variables (Boundary conditions data)	Outlet variables (Unknown values)
Mass flow rate [kg/s]	$\dot{m}_{Fo}, \dot{m}_{Bo}, \dot{m}_p, \dot{m}_{v2}$	$\dot{m}_v, \dot{m}_{Des}, \dot{m}_{Do}, \dot{m}_c, \dot{m}_{Fr}$
Temperature [K]	$T_{Fo}$	$T_B, T_D, T_{co}$
Pressure [Pa]		$P_i=f(T_B), P_o=f(T_D)$
Concentration	$X_{Fo}$	$X_{Bo}, X_C$
Vapour mass fraction		$X_{gDo}$
Mass [kg]		$m_v, m_B, m_{vT}, m_{vC}, m_{LC}$
Volume [ $m^3$ ]	$V_v, V_B, V_{vT}, V_{vC}, V_{LC}$	$x_{gDo}$
Density [ $kg/m^3$ ]		$\rho_{vT} = \rho_{gas}(T_B), \rho_B = \rho_{liq}(T_B), \rho_D=f(T_D)$

## 3. NUMERICAL RESULTS

First validation analysis of the model has been carried out comparing the experimental results and the numerical data of (Namine et al. 2014). The case presented is based on a mechanical vapor compression experimental desalination unit (MVC) producing  $5m^3/day$  of destilated water. After that, an illustrative numerical analysis is shown considering steady state and transient cases for a MVC system prototype capable to produce around  $1m^3/day$ .

### 3.1 Experimental validation

Based on (Namine et al. 2014) experimental results and numerical data, different own numerical results are compared: i) evaporation pressure and temperature to determine vapor conditions inside evaporator; ii) condensation pressure to determine destilation conditions; iii) brine mass and destilated water mass produced; iv) heat transfer condenser/evaporator area and global heat transfer; v) salt water at the inlet of condenser/evaporator and vi) power consumption per mass unit production.

**Table 2:** Numerical results model validation.

	Experimental data (Namine et al. 2014)	Numerical results (Namine et al. 2014)	Numerical results actual model
Evaporation temperature ( $T_B$ ) [ $^{\circ}C$ ]	69.8	69.1	70.0
Evaporation pressure ( $p_i$ ) [bar]	0.350	0.312	0.318
Condensation pressure ( $p_o$ ) [bar]	0.450	0.405	0.405
Brine mass flow ( $m_B$ ) [kg/h]	415	321	407
Product mass flow ( $m_p$ ) [kg/h]	210	309	224
Sea water mass flow ( $m_{Fo}$ ) [kg/h]	630	630	630
Sea water temperature ( $T_{Fo}$ ) [ $^{\circ}C$ ]	68.0	69.4	68.5
Global coefficient ( $UA$ ) <sub>T</sub> [kW/K]	Not available	42.16	46.58
Compressor specific work [kJ/kg]	Not available	50.71	47.67

The numerical results obtained with the actual model are presented in Table 2, these show a very good agreement with the experimental data for 70°C of salt water evaporation temperature considered (Namine et al. 2014). The numerical results obtained from the actual model for the mass flows of brine and distilled water produced is closer to experimental data than Namine's numerical results. Differences on compressor specific work are around 6% between both numerical results models.

After this experimental validation, an additional numerical comparison has been carried between both models at different salt water evaporation temperatures. Again the numerical comparative results show in Table 3 present a very good agreement. Differences on global heat transfer coefficient can be explained due to different coefficient correlations used from technical literature.

**Table 3:** Numerical comparison: (A) Namine's numerical results; (B) Actual numerical model.

	A	B	A	B	A	B	A	B
Evaporation temperature ( $T_B$ ) [°C]	65		70		75		80	
Condensation pressure ( $p_o$ ) [bar]	0.325	0.325	0.405	0.405	0.500	0.500	0.615	0.615
Sea water temperature ( $T_{Fo}$ ) [°C]	64.42	64.5	69.42	69.5	74.42	74.5	79.42	79.5
Global coefficient ( $UA$ ) <sub>T</sub> [kW/K]	41.82	47.6	42.16	46.58	42.33	45.73	42.67	45.22
Compressor specific work [kJ/kg]	50.12	47.35	50.71	47.67	51.29	47.72	52.00	48.23

### 3.2 Numerical illustrative cases

In order to explore numerical model capabilities and offer a numerical analysis based on different parameters influence on MVC optimization, 3 different illustrative cases are here presented. 1) Transient case with constant electrical feed; 2) Dynamic case modifying compressor power due to MVC working expected conditions and; 3) Dynamic case with variable compressor power consumption as a function of external meteorological conditions (solar radiation and ambient temperature) considering Barcelona, June month conditions for renewable cases.

#### 3.2.1 Steady state case

Figure 2 left shows the studied case with a constant compressor power consumption of 2850 W capable to move 800 m<sup>3</sup>/h of vapor from the evaporator to the condenser, for these working conditions the compressor speed is constant at 1595 rpm. Under these conditions Figure 2 right shows the accumulated seawater, distilled water and brine produced along the time working during 9 hours keeping constant temperature and pressure working conditions of both evaporator and condenser.

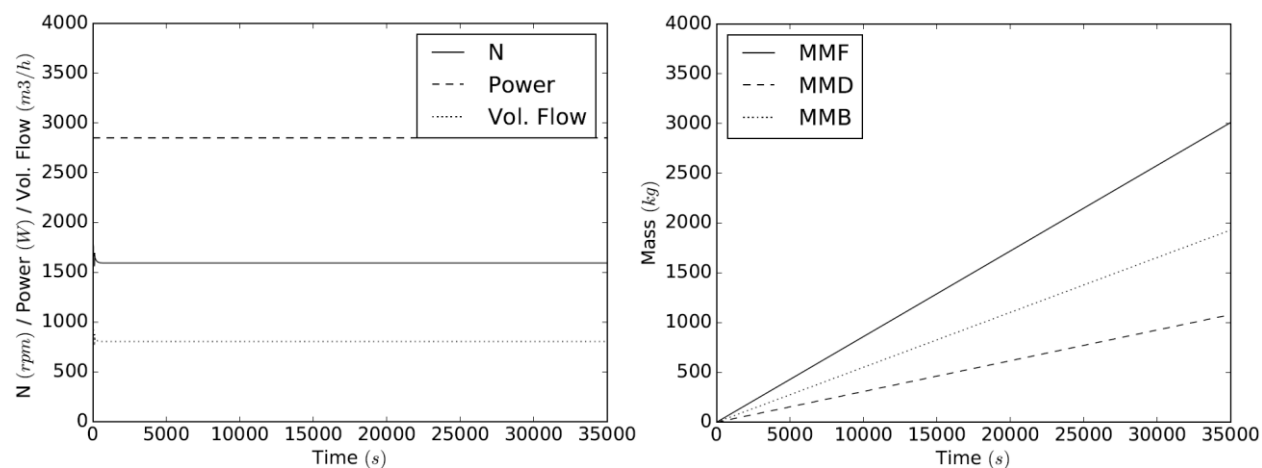
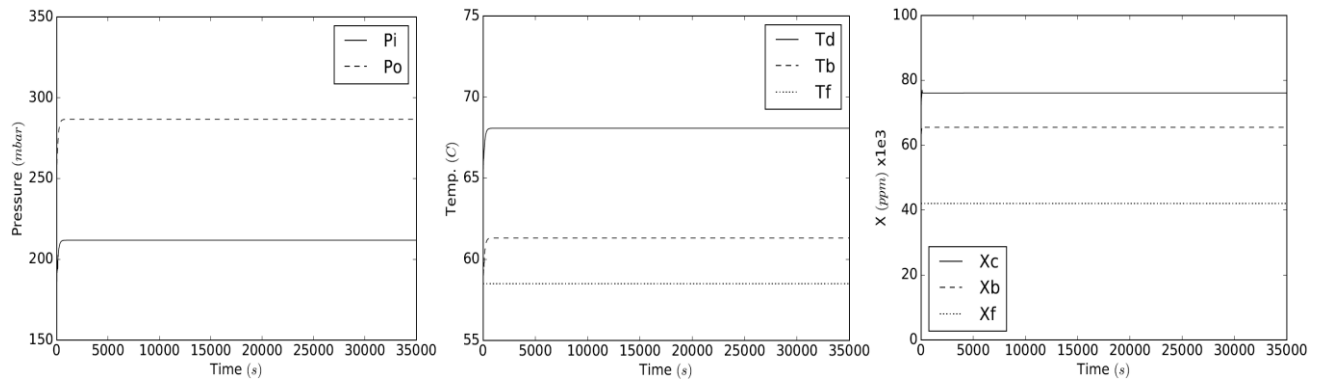

**Figure 2:** Compressor working conditions and accumulated MVC desalination system mass flow rates.

Table 4 shows input data conditions and outputs values for the studied case, while Figure 3 depicts both, evaporator and condenser pressures evolution, temperatures and mass concentrations along time, tending immediately to an asymptotic and steady values.

**Table 4:** Input conditions and outputs for 3.2.1 studied case.

Input conditions		Output values	
Evaporation temperature ( $T_B$ ) [ $^{\circ}\text{C}$ ]	61	Brine mass flow ( $m_B$ ) [kg/h]	407
Concentration ( $X_f$ ) [ppm $\times 1e^3$ ]	42	Product mass flow ( $m_p$ ) [kg/h]	224
Condensation pressure ( $p_o$ ) [bar]	0.286	Sea water mass flow ( $m_{F_o}$ ) [kg/h]	630
Sea water temperature ( $T_{F_o}$ ) [ $^{\circ}\text{C}$ ]	58.5	Global coefficient ( $UA$ ) <sub>T</sub> [kW/K]	10.7
		Compressor specific work [kJ/kg]	54.25

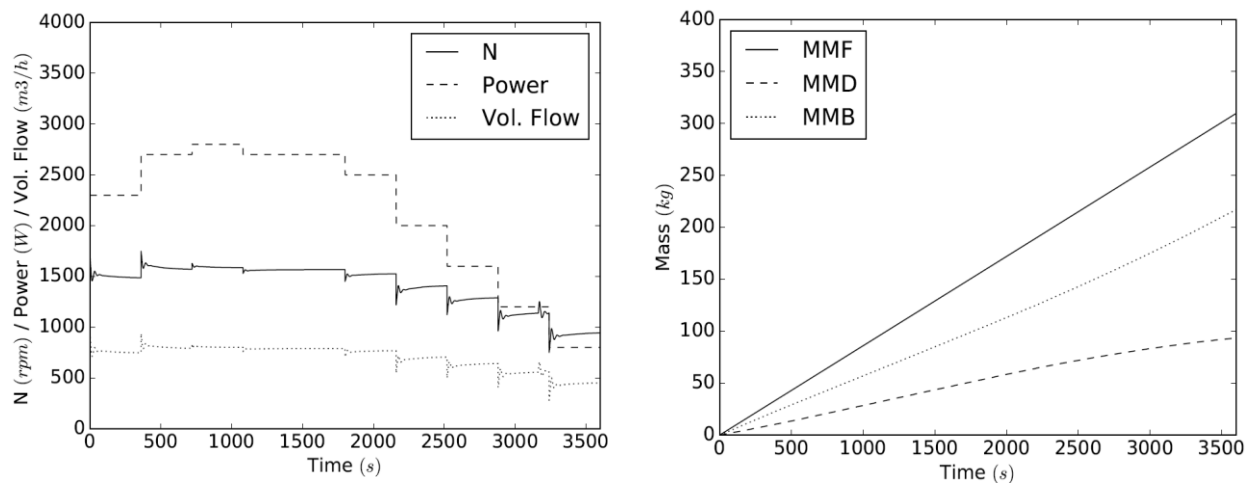

**Figure 3:** Blower pressures, evaporator/condenser temperatures and concentration flows evolution.

### 3.2.2 Transient state case

A second case is analyzed looking for dynamic system behavior, controlling a variable speed compressor depending on power consumption required by MVC system and changing every 6 minutes during 1 hour of process.

Figure 4 left shows the compressor rotation speed between 1000 and 1500 rpm, with a power consumption between 1000 W and 2750 W, allowing a volumetric flow ranging from 500 to 800  $\text{m}^3/\text{h}$  of vapor from the evaporator to the condenser. In the same way, Figure 4 right shows the accumulated seawater, distilled water and brine produced along the time working during 1 hours of simulation.



**Figure 4:** Compressor working conditions and accumulated MVC desalination system mass flow rates.

Figure 5 shows the evaporator and condenser pressures evolution, the temperatures and the mass concentrations along time. The transient evolution of all these variables is highlighted in these Figures, where pressure and temperatures are continuously decreasing also when compressor speed is constant, while mass concentration changes due to compressor speed variations but keeps more constant when compressor speed does not change.

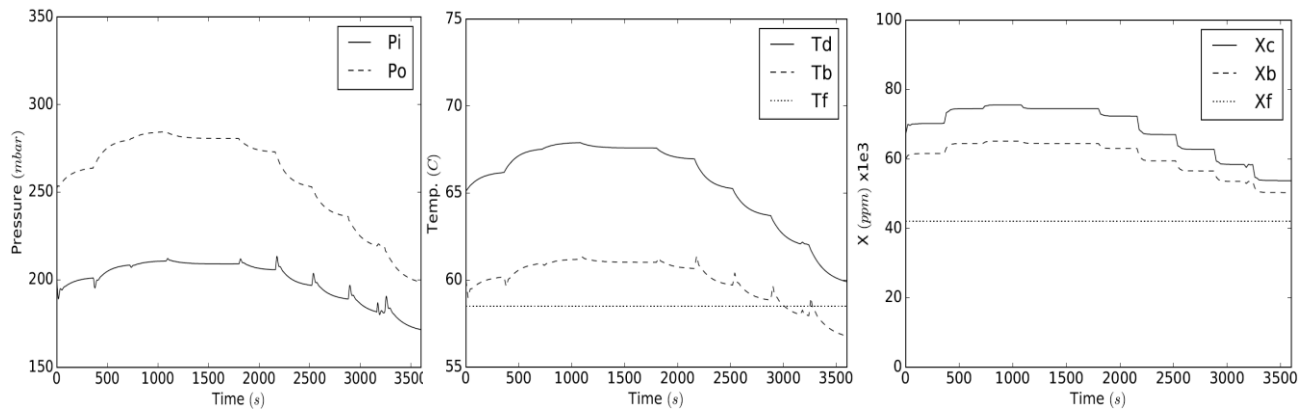

**Figure 5:** Blower pressures, evaporator/condenser temperatures and concentration flows evolution

### 3.2.3 Transient and intermittent state case

Finally, a third case is proposed where compressor rotation speed, and consequently power consumption is function of external weather conditions coming from solar radiation and ambient temperature detailed in Table 5 considering Barcelona ambient condition during one day at middle June, assuming that the system is installed in Barcelona.

**Table 5:** External ambient conditions from Barcelona city for 3.2.3 studied case.

Hour	Radiation (W/m <sup>2</sup> )	Ambient Temperature (°C)
9:00	515	17.2
10:00	684	18.1
11:00	771	19.8
12:00	860	20.6
13:00	811	21.1
14:00	801	21.9
15:00	734	22.0
16:00	722	20.9
17:00	521	19.9
18:00	371	19.1

A group of photovoltaic devices should be used to transform the solar radiation in electrical energy, which will be used to feed the compressor and pumps. The radiation data is a parameter needed to evaluate the energy source, together with the photovoltaic panel efficiency and the effective area used. The electric power evaluated is used to calculate the compressor velocity and the volumetric flow displaced. A sunny day of June has been chosen to evaluate the energy availability and variability along the day. Ten hours have been simulated with the aim of obtaining 1m<sup>3</sup>/day of distilled product.

For this case, Figure 6 left shows the compressor rotation around 1500 rpm, with a power consumption between 2000 W and 4000 W, allowing a volumetric flow ranging from 700 to 800 m<sup>3</sup>/h of vapor from the evaporator to the condenser. In the same way, Figure 6 right shows the accumulated seawater, distilled water and brine produced along the time working during 10 hours of simulation.



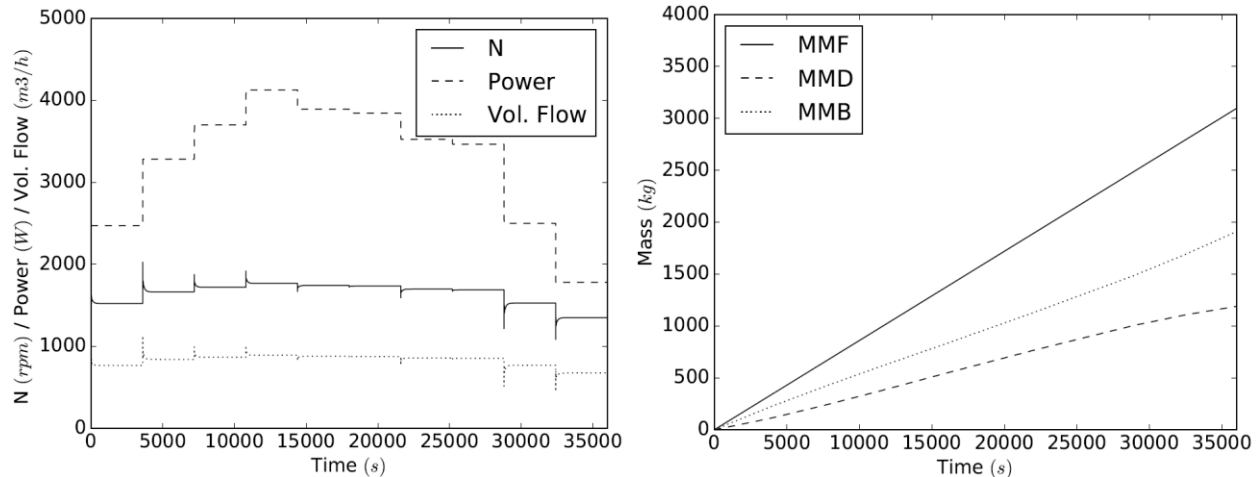

**Figure 6:** Compressor working conditions and accumulated MVC desalination system mass flow rates.

Figure 7 depicts the evaporator and condenser pressures evolution, the temperatures and the mass concentrations along time. In this case, transient evolution of all these variables show transient effect during compressor speed changes tending to asymptotic value until next compressor speed modification.

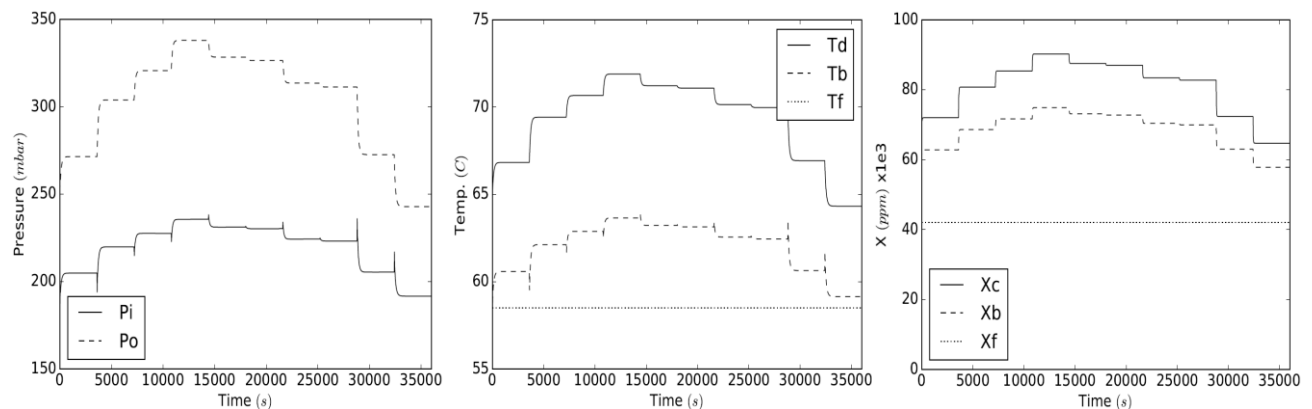

**Figure 7:** Blower pressures, evaporator/condenser temperatures and concentration flows evolution.

## 4. CONCLUSIONS

The present paper shows a numerical model capable to virtually reproduce a mechanical vapor compressor MVC desalination system under real transient working conditions. Mathematical formulation and numerical procedure is detailed with special emphasis on condensation/evaporation phenomena analysis. The model has been fully validated against experimental data and similar models from scientific literature showing better results in comparison with these other models. First illustrative results are depicted in order to show the influence on compressor speed (or power consumption) depending on working conditions conditioned by external ambient conditions. Thus, the model not only allows evaluating power consumption and energy need to obtain the distilled water expected, but also the influence of different variables on the MVC system behavior from optimization design purposes.

## NOMENCLATURE

$h$	enthalpy [kJ/kg]	$T$	temperature [K]
$m$ ,	mass [kg]	$u$	internal energy [kJ/kg]
$\dot{m}$	mass flow [kg/s]	$UA$	global heat transf, coef. [W/K]
$M$	Molecular mass [g/mol]	$V$	Volume [ $m^3$ ]
$p$	pressure [Pa]	$x$	mass fraction
$R$	Constant gases [J/molK]	$X$	concentration

### Subscript

B	brine	i	inlet
C	condenser	nc	non-condensable
D	desalinized water	o	outlet
Des	deareator	T	tubes
F	seawater	v	vapor

## REFERENCES

- Bodalal, A., Abdul\_Mounem, S.A., Salama, H.S., 2010, *Dynamic modeling and simulation of MSF desalination plants*, Jordan Journal of Mechanical and Industrial Engineering, Vol. 4, Number 3, 394-403.
- Damle, R., Rigola, J., Pérez-Segarra, C.D., Castro, J., Oliva, A., 2011, *Object oriented simulation of reciprocating compressors: Numerical verification and experimental comparison*. Int. Journal of Refrigeration, 34, 1989-1998..
- El-Khatib, K.M., Abd El-Hamid, A.S., Eissa, A.H., Khedr, M.A., 2004, *Transient model, simulation and control of a single-effect mechanical vapour compression (SEMVC) desalination system*, Desalination, 166, 157-165.
- Ettouney, H., 2006. *Design of single-effect mechanical vapor compression*. Desalination. 190, 1-15.
- J. Farnós, G. Papakokinos, J. Castro., S. Morales, A. Oliva. *Dynamic modelling of an air-cooled LiBr-H<sub>2</sub>O absorption chiller based on heat and mass transfer empirical correlations*. Proceedings of the 12th IEA Heat Pump Conference, 2017. Mazini, M.T., Yazdizadeh, A., Ramezani, M.H., 2014, *Dynamic modeling of multi-effect desalination with thermal vapor compressor plant*, Desalination, 353, 98-108.
- Namine H. Aly, Adel K. El-Fiqi, *Mechanical vapor compression desalination systems - a case study*, Desalination Vol. 158, pp 143-150, 2003.
- Plantikow, U., 1999, *Wind-powered MVC seawater desalination – operational results*, Desalination, 122, 291-299.
- Suryanarayana, K.V., Sharma, K.V., Sarma, P.K., Dharma, V., Reddy, D.M., 2011, *Experimental analysis of heat and mass transfer in a two stage jet cum packed bed deareator*, Int. Journal of Material Research, Electronics and Electrical Systems, Vol. 4, Number 1-2, 91-106

## ACKNOWLEDGEMENT

This research has been financed and supported by the **Spanish Government** through the project *GREEN-MVC Prototipo de sistema autónomo de desalación de agua por compresión mecánica de vapor a partir de fuentes de energía 100% renovables* - (Ref. RTC-2014-2056-5).