

1988

# Alternate Models of the Dynamics of a Refrigeration Compressor Shell

Massoud S. Tavakoli  
*Georgia Institute of Technology*

Rajendra Singh  
*The Ohio State University*

Follow this and additional works at: <https://docs.lib.purdue.edu/icec>

---

Tavakoli, Massoud S. and Singh, Rajendra, "Alternate Models of the Dynamics of a Refrigeration Compressor Shell" (1988).  
*International Compressor Engineering Conference*. Paper 637.  
<https://docs.lib.purdue.edu/icec/637>

This document has been made available through Purdue e-Pubs, a service of the Purdue University Libraries. Please contact [epubs@purdue.edu](mailto:epubs@purdue.edu) for additional information.

Complete proceedings may be acquired in print and on CD-ROM directly from the Ray W. Herrick Laboratories at <https://engineering.purdue.edu/Herrick/Events/orderlit.html>

# ALTERNATE MODELS OF THE DYNAMICS OF A REFRIGERATION COMPRESSOR SHELL

By

Massoud S. Tavakoli  
Assistant Professor  
The George W. Woodruff School of Mechanical Engineering  
Georgia Institute of Technology

and

Rajendra Singh  
Professor  
Department of Mechanical Engineering  
The Ohio State University

## ABSTRACT

A structural synthesis method based on state space mathematics (State Space Method) is used to model the free vibrations of a refrigeration compressor shell. Five models which progressively approximate the compressor shell geometry are analyzed. The results are compared with experimental data and bounded analytical solutions. The effects of adding positive curvature in the flat side of the cylindrical body of a compressor shell on its stiffness are also investigated.

## INTRODUCTION

Structures composed of shell elements (cylinders, spheres, cones, etc.) find a wide range of application in such areas as refrigeration systems, pressure vessels, nuclear reactors, aircraft, and rockets. One typical example is a welded refrigeration compressor shell which is the subject of this paper. There exists an acute need for synthesis methods applicable to compressor shell structures where recent efforts [1-3] have concentrated on reducing compressor noise in the middle to high frequency range (say 800 Hz to 3000 Hz) by modifying the shape of the compressor shells. The work in this area has been primarily of the trial-and-error and intuitive-reasoning nature with little analytical work or systematic experimentation.

Because of the difficulties associated with the exact modeling of such shell structures, the design guidelines have been traditionally [4,5] based on the well-known solutions for classical shells under classical boundary conditions (e.g. a simply supported cylinder). Recently, Irie et al. [6-8] used a method based on the transfer matrix approach to analyze cases such as a cone with a variable thickness, and a cone-cylinder combination. In this method, the governing equations for a shell are reformatted into a system of eight first order differential equations. These equations are then put into a state space formulation, and the transfer matrix relating the state vectors at different locations along the structure is computed. The State Space Method (SSM) shows a good degree of versatility and ease of application. Tavakoli [9], and Tavakoli and Singh [10] verified the method by applying it to various basic structural elements (cylinder, cone, sphere, etc.) whose solutions are well-known. They also demonstrated the applicability of SSM to several more complicated shell structures including a hermetic capsule (hemisphere-cylinder-hemisphere combination) and a refrigeration compressor shell.

In this paper, SSM is used to model the free undamped vibrations of a typical refrigeration compressor shell. Five models which progressively approximate the geometry of the compressor shell are analyzed and compared

with experimental data and with bounded analytical solutions. Effects of positive curvature and the shape of end caps on the stiffness of the compressor shell are also investigated.

## COMPRESSOR SHELL ANALYSIS

### Experimental Analysis

Figure 1 shows the cross-sectional view of the refrigeration compressor shell of interest with properties:  $E=207 \text{ GPa}$  ( $30 \times 10^6 \text{ psi}$ ),  $\rho=7800 \text{ kg/m}^3$  ( $0.283 \text{ lb/in}^3$ ) and  $\nu=0.3$ . While various shell elements are identified in this figure, some of the local attachments (pipe, tube, valve, etc.) are not shown. Also, the internal pump-motor assembly was taken out for the experimental modal analysis. The measured data were collected by exciting the structure (with air inside) with a shaker fed with a random signal. Over the frequency range of 0-2000 Hz, twelve resonant frequencies were detected which are given in Table 1. Further investigation established that the first six frequencies represent only three circumferential modes as the well-known modal splitting phenomenon for nearly axisymmetric structures [11] was observed. The correlation between the natural modes and frequencies is also given in Table 1. Natural frequencies identified as "bottom modes" correspond to modes which showed significant amplitudes in the bottom half of the compressor below the welded seam, and showed very little motion in the top half. Also, the end caps did not seem to have any significant vibrations for any of the resonances detected in this range.

### Analytical Modeling

For comparative purposes, five models of the compressor shell are analyzed using SSM. These models progressively approximate the compressor shell geometry. Model A is simply a shear diaphragmed circular cylinder which represents the simplest and the traditionally popular approximation of the compressor shell [4,5]. Model B is a circular cylinder closed with circular end plates which represents the simplest hermetic model of the compressor shell. The circular cylinder closed at its ends with spherical domes, shown in Figure 2, is Model C which represents a more realistic model of the compressor shell. In Model D, the transition between the cylinder and the spherical dome of Model C is modified by inserting a conical section between the respective substructures as shown in Figure 3. This is done to observe the effect of a more gradual transition between the cylinder and the spherical end cap on the natural frequencies and mode shapes. Finally, in Model E, the end caps of the compressor shell are modeled exactly by inserting a toroidal segment between the cylinder and the spherical dome of Model C as shown in Figure 1.

TABLE 1  
Experimentally Identified Natural Frequencies and Modes

$\bar{f}$ (Hz)	mode (m,n)
867 880	mode (0,3)
1090 1106	mode (0,2)
1143 1158	mode (0,4)
1551 1558 1649	bottom modes
1765 1838 1888	m=1 modes

## Results

In Table 2, SSM results for the lowest natural frequency corresponding to the first five circumferential mode numbers of these models are compared with the experimental results presented earlier. Since each measured circumferential mode corresponds to a pair of natural frequencies, the average of each pair of these split frequencies is listed as the experimental value. These results are compared graphically in Figure 4. Also included in this figure is the results for a free-free cylinder and a clamped-clamped cylinder which represent the lower and upper bounds of the natural frequencies, respectively.

The predicted natural frequencies for all five models seem to converge at higher values of the circumferential mode number,  $n$ . It seems that the cylindrical body becomes the primary vibrating substructure for the lower natural frequencies at higher values of  $n$ . In addition, these frequencies show minor sensitivity to the boundary configuration. At lower values of  $n$ , however, the more popular Models A and B fail to approximate the compressor shell properly.

For  $n > 1$ , Models C, D, and E predict the same trend as the experimental results, while the closest approximation of the compressor shell natural frequencies are generated by Model E. As mentioned previously, none of the end cap frequencies of the compressor shell were detected experimentally in the range of observed frequencies (0-2000 Hz). This is reinforced by Figure 4 which shows the end cap frequencies to be beyond 2000 Hz. It is speculated here that Model E is the most appropriate one to estimate the end cap vibrations.

TABLE 2  
Compressor Shell Models: Comparison of Natural  
Frequencies (Hz) between SSM and Experiment (EXP)

		MODEL									
n	EXP	A	B	C	D	E	$\Delta_A\%$	$\Delta_B\%$	$\Delta_C\%$	$\Delta_D\%$	$\Delta_E\%$
0	-	6394	477	3192	2675	2529	--	--	--	--	--
1	-	3050	1039	3539	3315	3132	--	--	--	--	--
2	1098	1644	1447	1330	1291	1236	50	32	21	18	12
3	874	1121	1098	1041	1012	964	28	26	19	16	10
4	1150	1289	1295	1269	1254	1220	12	13	10	9	6
5	-	1798	1813	1793	1781	1744	--	--	--	--	--

$$\Delta_x\% = 100X (\text{Model } x - \text{EXP}) / \text{EXP}$$

## Curvature Effects

Soedel [12] has analytically shown that the natural frequencies of a shear diaphragmed cylinder are monotonically increased if positive curvature ( $S$ ) is introduced in the flat side of the cylinder to generate a "barrel" shape as shown in Figure 5. He has also shown that the effect of negative curvature is an initial increase in the natural frequencies followed by a monotonic decrease after the curvature surpasses a critical amount. Furthermore, based on measured data, Lowery [1] concluded that the lowest natural frequency of a compressor shell can be increased by as much as one octave if discontinuities in both the surface and the curvature are removed. According to Lowery [1], the most effective method of adding curvature to a cylinder is to positively curve the flat side, and the stiffness of the barrel shape can be further increased by eliminating the abrupt changes in the radii of curvature that occur at the "blend-points" between the cylinder and the end caps.

SSM is used here to examine the effect of adding various degrees of positive curvature to the unwelded shear diaphragmed cylinder (Model A). The results for the lowest natural frequencies corresponding to the circumferential modes  $n=2$  through 5 are presented in Table 3. This table shows that an octave increase in the lowest natural frequency ( $m=0, n=4$ ) of this cylinder requires that approximately 10% ( $S/L=0.1$ ) positive curvature be added to the flat side of the cylinder. Even though Lowery [1] has not given

the precise dimensions of his compressor shells, the provided diagrams indicate that he also employed roughly the same percentage of curvature in order to obtain an octave increase in the lowest natural frequency.

As for the effect of eliminating abrupt curvature changes at the junctions of the end caps and cylinder, Figure 4 should be examined once again. Careful comparison of Models B, C, D, and E shows that the introduction of positive curvature in the end plates of Model B increases the end plate frequencies drastically. However, contrary to Lowery's claim [1], joining the end caps to the cylindrical body in a more continuous fashion reduces the natural frequencies of the overall structure. This effect is intuitively supported when one recognizes that a circular plate provides a more rigid boundary condition for the cylindrical body than any other end cap studied here. Also, one can argue that the more continuous attachment of the end caps to the cylinder seems to add to the "effective length" of the cylinder, hence reducing its natural frequencies.

TABLE 3  
Effect of Positive Curvature S on Natural  
Frequencies (Hz) of Unwelded Compressor Shell Model A

n	S/L=0.000	S/L=0.025, Δ%	S/L=0.050, Δ%	S/L=0.100, Δ%
2	1752	2059 , 18	2328 , 33	2818 , 61
3	1087	1464 , 35	1832 , 68	2530 , 133
4	1034	1310 , 27	1676 , 62	2429 , 135
5	1368	1468 , 7	1757 , 28	2451 , 79

$$\Delta\% = 100X (f_{S/L} - f_0) / f_0$$

#### CONCLUDING REMARKS

A structural synthesis method based on state space mathematics was utilized to model the free vibrations of a refrigeration compressor shell. Five models which progressively approximate the compressor shell geometry were studied. It was concluded that traditionally popular simplistic models such as a shear diaphragmed cylinder fail to approximate the compressor shell reasonably, especially at lower natural frequencies. Comparison with the measured data showed that the best estimation of the compressor shell natural frequencies were generated by the model which approximated the compressor shell geometry the closest (Model E). Finally, it was shown that introducing positive curvature in the flat side of the cylindrical body of a compressor shell is an effective means of increasing its stiffness.

#### ACKNOWLEDGEMENTS

The authors would like to thank Carlyle Compressor Company, Carrier Corporation, and especially Mr. Thomas Katra for supporting this study. We are also indebted to ASHRAE for providing partial financial support.

#### REFERENCES

1. D.C LOWERY 1984, Proceedings of International Compressor Engineering Conference at Purdue, 285-290. An improved shape for hermetic compressor housing.
2. F. SAITO, N. OKUBO, T. UETSUJI AND S. MOEDA 1980, Proceedings of Purdue Compressor Technology Conference, 228-234. Noise reduction of hermetic compressor by improving on its shell shape.
3. K. TOJO, S. MACHIDA, S. SAEGUSA AND T. HIRATA 1980, Proceedings of Purdue Compressor Technology Conference, 235-242. Noise reduction of refrigeration compressors.

4. R. N. ARNOLD and G. B. WARBURTON 1953 Proceedings of Institution of Mechanical Engineers 167, 62-80. The flexural vibrations of thin cylinders.
5. L. L. FAULKNER and J. E. HAMILTON 1971 Proceedings of International Congress on Refrigeration, Washington, D.C. Refrigeration compressor shell vibration and sound radiation.
6. T. IRIE, G. YAMADA and Y. KANEKO 1982 Journal of Sound and Vibration 82, 83-94. Free vibration of a conical shell with variable thickness.
7. T. IRIE, G. YAMADA and Y. MURAMOTO 1984 Journal of Sound and Vibration 95, 31-39. Free vibration of joined conical-cylindrical shells.
8. T. IRIE, G. YAMADA and T. TANAKA 1984 Journal of Sound and Vibration 95, 249-259. Free vibration of a circular cylindrical double-shell system interconnected by several springs.
9. M. S. TAVAKOLI 1987, Ph.D. Thesis, The Ohio State University. Dynamic synthesis of joined/hermetic shell structures using the state space method.
10. M. S. TAVAKOLI AND R. SINGH 1988, submitted to the Journal of Sound and Vibration. Eigensolutions of joined/hermetic shell structures using the state space method.
11. W. SOEDEL 1980 Proceedings of Purdue Compressor Technology Conference, 259-262. Simple mathematical models of mode splitting of hermetic compressor shells that deviate from axisymmetry.
12. W. SOEDEL 1981. Vibrations of Shells and Plates. New York: Marcel Dekker, Inc.

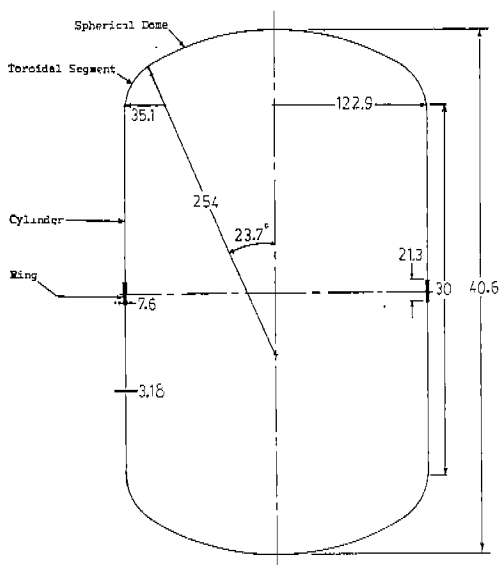

Figure 1: Hermetic Refrigeration Compressor Shell  
(Model E) (all dimensions in mm)

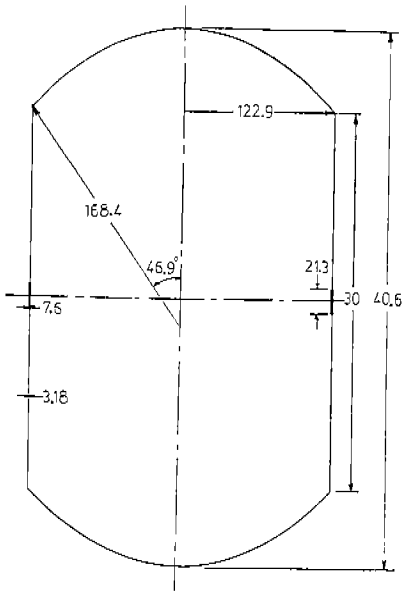

Figure 2: Cylinder with Spherical End Caps (Model C) (all dimensions in mm)

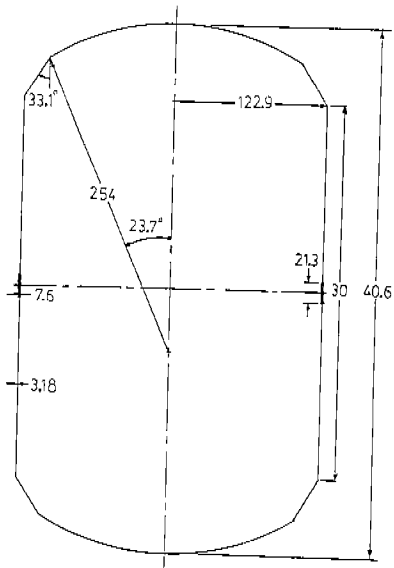

Figure 3: Cylinder with Modified End Caps (Model D) (all dimensions in mm)

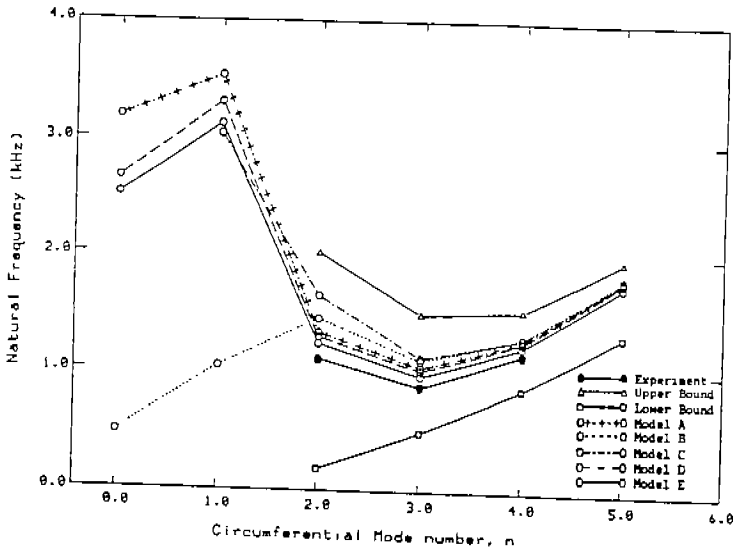

Figure 4: Comparison of Compressor Shell Models and Experiment

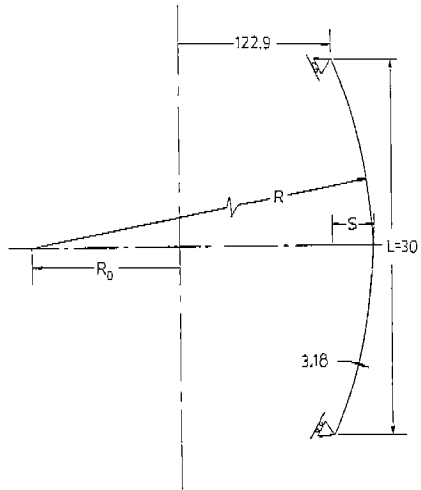

Figure 5: Shear Diaphragmed Cylinder with Positive Curvature - (all dimensions in mm)