

1986

Experimental Analysis of Stress on the Valves in Refrigerant Compressor by the Nickel Electroplating Method

I. Tarutani

H. Tanaka

K. Sumiyoshi

M. Seika

Follow this and additional works at: <https://docs.lib.purdue.edu/icec>

Tarutani, I.; Tanaka, H.; Sumiyoshi, K.; and Seika, M., "Experimental Analysis of Stress on the Valves in Refrigerant Compressor by the Nickel Electroplating Method" (1986). *International Compressor Engineering Conference*. Paper 562.
<https://docs.lib.purdue.edu/icec/562>

This document has been made available through Purdue e-Pubs, a service of the Purdue University Libraries. Please contact epubs@purdue.edu for additional information.

Complete proceedings may be acquired in print and on CD-ROM directly from the Ray W. Herrick Laboratories at <https://engineering.purdue.edu/Herrick/Events/orderlit.html>

EXPERIMENTAL ANALYSIS OF STRESS ON THE VALVES IN REFRIGERANT
COMPRESSOR BY THE NICKEL ELECTROPLATING METHOD

¹ I. Tarutani, ¹ H. Tanaka, ² K. Sumiyoshi, and ³ M. Seika

¹ Daikin Industries Ltd., Compressor Dept.3-12 Chikko-
shinmachi, Sakai, Osaka

² Daikin Industries Ltd., CAE center 1304, Kanaoka-cho,
Sakai, Osaka

³ Faculty of Engineering, Nagoya University, Chikusaku, Nagoya

ABSTRACT

To determine the magnitude and location of the maximum stress on the suction valve during the actual compressor operation, the nickel electroplating method has been developed. As comparing the stress data obtained with the failed valve during actual use, it was found that this method was available .

Furthermore, the standard deviation of the suction valve stress in the field was evaluated using a statistical approach for predicting the probability of the suction valve failure.

INTRODUCTION

The demand to improve the compressor reliability has been enhanced since the failure of a single compressor can result in shutdown of either the airconditioning units or the plants using these units. The most important factor to improve the compressor reliability is reducing the probability of failure on the compressor suction valves where the highest stress occurs.

There are two types of approach to determine the stress on valves : the analytical approach and the experimental approach. In the former approach, the finite element method is used (1,2). However, it is noteworthy that this method fails to take into account the variation in the force area (3). Using the latter approach, Kumasawa, et al. measured the stress on suction valves using the copper electroplating method (4).

Unfortunately, since their measurement was limited to the lower temperature range: up to 80°C, stress data for the higher temperature range: up to 120°C, could not be obtained.

Therefore, the nickel electroplating method has been developed for measuring the stress of suction valves under the standard operating condition. The present paper describes the nickel electroplating method and a statistical approach to predict the reliability of the suction valve.

EXPERIMENTAL METHOD

Stress measurement by the electroplating method

In the electroplating method of stress analysis, the elastic surface stress of a specimen coated with electrodeposited copper or nickel is measured by observing flecks (slip bands) in the deposited layer, resulting from repeated loads acting on the specimen (5,6,7).

On the contrary, grain growth in the deposited layer is dominated by the repeated shearing stress acting on the surface of the specimen. Therefore, the calibration value of the deposited layer is evaluated from the relationship between the proper stress at which the flecks begin to appear and the number of repeated bending. The standard photographs of flecks are obtained from the calibration test for a specified N.

Consequently, a specimen coated with the same plating is subject to a repeated load under the specified N. The appearance of flecks on the specimen is compared with the standard photographs to estimate the stress value.

Plating conditions

The plating was consisted of two layers: a preliminary deposit of alkaline copper in a copper cyanide bath and an additional deposit of nickel in the sulfamate bath. The composition of plating solutions and plating conditions used are shown in Table 1,2.

In the present measurement, the copper deposite obtained were about 1 μ m in thickness. Specimens were prepared by the following surface treatments: polishing with 800-emery paper, treating with calcium carbonate and dilute sulfuric acid.

The watts-type solution used in the previous work (8,9) was agitated frequently during the plating operation so that

hydrogen bubbles on the surface of deposits could be removed. By using the sulfamate solution, however, few hydrogen bubbles could be found and the solution needed no agitations.

Consequently, the plating obtained had no pits and pinholes, and its surface was markedly smooth and fine, compared with that of the Watts-type plating.

Applying the plating conditions shown in Table 1,2 to present measurement, the thickness of the plating was about 6 μm . Accordingly, it should be expected that the strain in the plating is identical with the cyclic strain on the surface of base metal.

Calibration test

The repeated bending fatigue testing machine operating at 1800 rpm, as shown in Fig. 1, was used for repeated bending tests in high temperature range: The testing temperature was determined with the temperature in an electric furnace attached to the testing machine. The temperature was measured by using a copper-constantan thermocouple. The testing machine was started to operate after the temperature of specimens kept at constant.

A repeated bending test was made under the condition that bending moment M loaded on a steel plate (1% Carbon) illustrated in Fig. 2.

With an increase in the number of stress repetitions N , flecks on the plating surface appeared first in the area closest to the clamped edge, and also the discoloration caused by the flecks enlarged gradually toward the increase of x . As the distance x of the discolored part is measured, the proper stress in tension-compression σ_p and the proper stress in cyclic shear τ_p are expressed as

$$\sigma_p = 2 \tau_p = \frac{6M}{bh^2}$$

Fig. 3 shows the relationship between Temperature and τ_p .

Stress measurement of the suction valve

Prior to testings, the suction valve behavior was observed using the strain gage to determine the number of stress repetitions on the valve. Fig. 4 shows the data of the strain gage test.

Although the suction valve fluttered several times during each suction stroke, it was clear that the amplitudes of fluttering were so small that the number of stress repetitions corresponded to that of compressor rotations. This is due to the reason that no flecks appears in the electroplate.

In actual testing, the suction valve coated with nickel under the condition shown in Table 1 was installed in the tested compressor. After operating the compressor under the condition shown in Table 3, using a microscope, the appearance of flecks on the valve was compared with the standard photographs to obtain the stress value.

RESULTS AND DISCUSSION

Comparison of the failed suction valve and the stress distribution obtained

Fig. 5 presents a comparison of a valve that failed during actual use,(a), and the stress distribution obtained from the nickel electroplating method,(b). It was found that the location of the initial fracture was at the corner of the spoke and the ring, as indicated with an arrow in Fig. 5(a), and also in Fig. 5(b), the maximum stress level appeared at the same location.

Furthermore, Fig. 6 shows the result of the similar comparison of the different suction valve type. The location of the initial fracture was at the adjacent to the clamped edge as shown in Fig. 6(a),and also in Fig. 6(b), the maximum stress level found to appear at the same point .

These results demonstrated that the nickel electroplating method was available to determine the magnitude and location of the maximum stress on the suction valves during the actual compressor operation.

A comparison of the experimental and the analytical stress for a bar and ring suction valve

A bar and ring suction valve which is widely used in the hermetic compressor is shown in Fig. 7. This valve is suitable to reduce the pressure difference across the valve, however, the maximum stress level is unlimited, since there is no valve stopper to restrict the valve lift.

Therefore, the measurement for obtaining the maximum stress level using the nickel electroplating method has been carried out under the standard operating condition mentioned early. As shown in Fig. 8, it is clear that the maximum stress level is located in the inside of the ring on the Y axis.

On the other hand, the static stress analysis using the finite element method was attempted under the following conditions.

1, Mesh configuration: Fig. 9 shows the finite element mesh for the calculation. Due to geometrical symmetry about x and y axes it was only necessary to analyze one quarter of the valve.

2, Boundary conditions: The nodes from 13 through 18 to simulate a contact with a step on the valve support ring were simply supported.

3, Load conditions: Since the actual pressure loads on the valve were unknown, several steps of the uniform loads with increasing magnitude were applied to the area of the ring until the analytical results agreed with the experimental stress levels.

Fig. 10 shows the maximum shear stress contours as the uniform load on the ring attained to .04 MPa. In Fig. 10, it was found that the magnitude and distribution of the analytical stress is very similar to those of the experimental stress as shown in Fig. 8. In addition, Fig. 11 shows the deformation contours of the valve during the uniform load of 0.04 MPa. The dotted line illustrated in Fig. 11 indicates the mode shape.

From these comparison, the uniform load and deformation in z direction were applied to the performance analysis of the compressor and the valve lift measurement for the calibration parameters, respectively.

RELIABILITY PREDICTION OF SUCTION VALVE

Statistical approach to design

The purpose of this section is to provide a statistical approach to predict the reliabilities of the suction valves, since the loads applied to the suction valves varied according to the outdoor temperature in the field.

Fig. 12 shows the distributions of the suction valve stress, σ_1 , and fatigue strength of the materials, σ_w . Where $\bar{\sigma}_1$ and S_1 are the mean and the standard deviation of σ_1 , respectively. And also, $\bar{\sigma}_w$ and S_w are those of σ_w . The factor of safety is given by

$$S = \frac{\bar{\sigma}_w}{\bar{\sigma}_1} \quad (1)$$

However, the two frequency distributions overlap and it is possible for $\bar{\sigma}_1 > \bar{\sigma}_w$, which is the condition for failure (10). The probability of failure is given by

$$P = \int_{-\infty}^0 Y(\sigma_{w-1}) d\sigma_{w-1} \quad (2)$$

In the case where the distributions of σ_w and σ_1 follow the normal distribution, the overlapping distribution $Y(\sigma_{w-1})$ also follows the normal distribution shown at the left in Fig. 12. In order to standardize the distribution curve, the following equations are used

$$t = \frac{\sigma_{w-1} - \bar{\sigma}_{w-1}}{\left(\frac{S_w^2 + S_1^2}{w+1} \right)^{1/2}} \quad (3)$$

and

$$-t = -\frac{\bar{\sigma}_{w-1}}{S_{w-1}} \quad (4)$$

where $\bar{\sigma}_{w-1}$ is the mean value and S_{w-1} is the standard deviation $Y(\sigma_{w-1})$. The probability of failure is given

$$P = \int_{-\infty}^{-t} \frac{1}{\sqrt{2\pi}} \exp\left(-\frac{t^2}{2}\right) dt \quad (5)$$

Substituting Eq.(4) into Eq.(1) gives

$$S = \frac{\sqrt{1 - (1-t) \frac{\delta_w^2}{R} (1-t) \frac{\delta_l^2}{R}}}{1 - t \frac{\delta_w^2}{R}} \quad (6)$$

where δ_w and δ_l are the coefficients of variation of $\bar{\sigma}_w$ and $\bar{\sigma}_l$, respectively.

$$\delta_w = \frac{S_w}{\bar{\sigma}_w}, \quad \delta_l = \frac{S_l}{\bar{\sigma}_l} \quad (7)$$

Standard deviation of the stress in the field

In predicting the probability of the suction valve failures using Eq.(3),Eq.(4), and Eq.(5), it is need to determine $\bar{\sigma}_w$, S_w , $\bar{\sigma}_l$, and S_l , respectively. While $\bar{\sigma}_w$ and S_w have been obtained from the literature, $\bar{\sigma}_l$ and S_l are unknown.

The mean $\bar{\sigma}_l$ was evaluated with the modified Goodman diagram shown in Fig. 13. In this figure, $\bar{\sigma}_p$ is the maximum principal stress obtained from the nickel electroplating method under the standard operating condition. On the other hand, P in Eq.(5) was estimated by summing up the valves that failed during actual use. The value of S_l was evaluated from Eq.(5),Eq.(6), and Eq.(7).

Fig. 14 shows the relationship between the S_l and valve thickness for 8 different suction valve types. As the thickness increases from .3 to .6mm, S_l decreases 103 to 44MPa. It might be understood that these data provide the probability of the suction valve failure in the field in Eq.(5). But it is appropriate to use the upper bound of $S_l = 103\text{MPa}$, since the lower value of S_l may result in underestimating it.

CONCLUSIONS

In the present study, the nickel electroplating method has been attempted to measure the suction valve stress. The following conclusions can be made:

1 Comparison of the failed valves and the stress distributions obtained indicated that this method was available to determine the magnitude and location of the maximum stress on the suction valves during the actual compressor operations.

2 The uniform load and deformation of the bar and ring suction valve were obtained from the comparison of the experimental and the analytical (the finite element method) results.

3 The standard deviations of the field stress were estimated using the statistical approach from the stress data obtained and the probability of the suction valve failures during the actual use.

REFERENCES

- (1) S.Papastergiou, J.Brown, and J.MacLaren, "The Dynamic Behaviour of Valve Reads in Reciprocating Gas Compressor Analytical Study", Proceeding of the 1980 Purdue Compressor Technology Conference, July 23-25(1980),263.
- (2) G.C.Griner, G.W.Gatecliff, and R.Richardson, "Static and Dynamic Analysis of Reed Valves using a Minicomputer Based Finite Element System", Proceeding of the 1980 Purdue Compressor Technology Conference, July 23-25(1980),172.
- (3) L.Boswirth, "Flow Force and the Tilting of Spring Loaded Valve Plate Part 1", Proceeding of the 1980 Purdue Compressor Technology Conference, July 23-25(1980),185.
- (4) M.Kumasawa, and A.Futakawa, "Evaluation of Compressor Valve Stress by means of Copper Electrodeposit Technique", Proceeding of the 1984 Purdue Compressor Technology Conference, July 11-13(1984),479.
- (5) H.Okubo, "Electroplating Method of Stress Analysis", Memoirs Fac.Eng.,Nagoya Univ.,20(1968),1.
- (6) M.Seika, K.Hosono, and H.Ota, "Measurement of Cyclic Stresses in High Temperature Range Using Nickel Electroplating", Bulletin of the JSME,22(1979),793.
- (7) M.Seika, Y.Nagase, K.Hosono, and N.Taketani, "Fundamental Studies on the Copper and Nickel Electroplating Methods of Stress Analysis", Bulletin of the JSME, 25(1982), 1653.

(8) M.Seika, K.Hosono, H.Ota, and A.Kato, "Measurement of Cyclic Stresses in High Temperature Range Using Nickel Electroplating", Bulletin of the JSME,19(1976),863.

(9) M.Seika, K.Hosono, and A.Kato, "Measurement of Cyclic Stresses in High Temperature Range Using Nickel Electroplating", Bulletin of the JSME,19(1976),871.

(10) E.B.Haugen, "Probabilistic Mechanical Design", Wiley-Interscience, New York, 1980.

Table 1 Composition of plating solution and plating conditions (Alkaline copper plating)

Copper cyanide	CuCN	23 g
Sodium carbonate	Na ₂ CO ₃	10 g
Sodium cyanide	NaCN	30 g
Distilled water	H ₂ O	1 L
Bath temperature		30°C
Plating duration		1 min
Current density		120 A/m ²
Bath voltage		1.4 - 1.5 V

Table 2 Composition of plating solution and plating conditions (Nickel plating)

Nickel sulfamate	Ni(NH ₂ SO ₃) ₂ ·4H ₂ O	300 g
Nickel chloride	NiCl ₂ ·6H ₂ O	30 g
Boracic acid	H ₃ BO ₃	30 g
Distilled water	H ₂ O	1 L
ph		4.8
Bath temperature		50°C
Plating duration		10 min
Current density		250 A/m ²
Bath voltage		1.4 - 1.6 V

Table 3 Standard operating condition

Suction pressure	.607 MPa
Discharge pressure	2.26 MPa
Suction gas temperature	13 °C

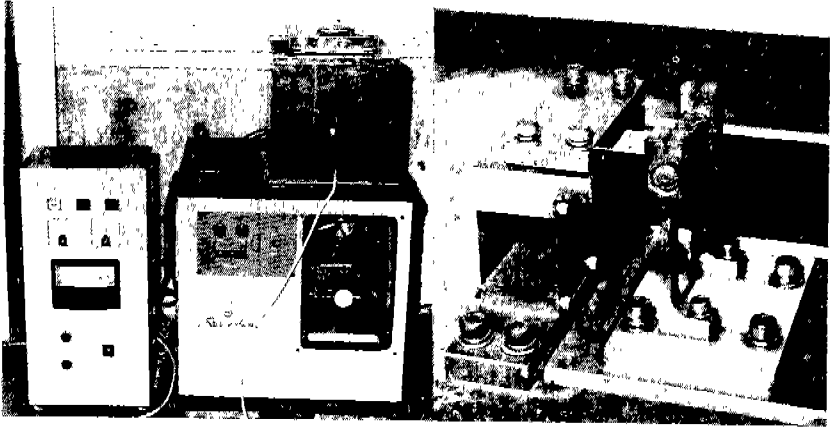

Fig. 1 Repeated bending fatigue testing machine

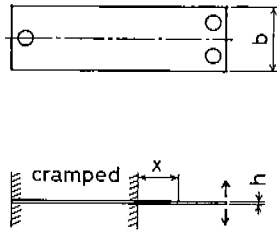

Fig. 2 Calibration specimen

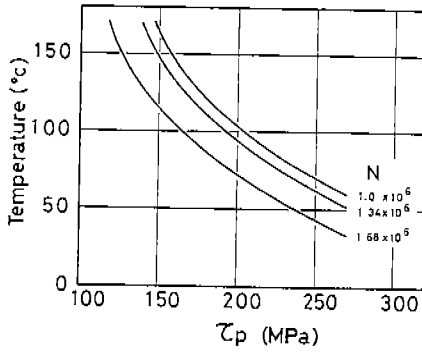

Fig. 3 Temperature - τ_p curve

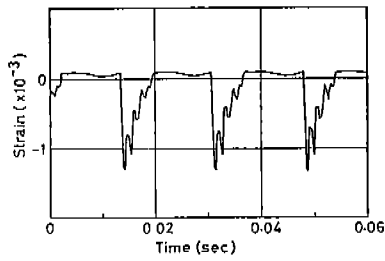

Fig. 4 Transient variation of strain

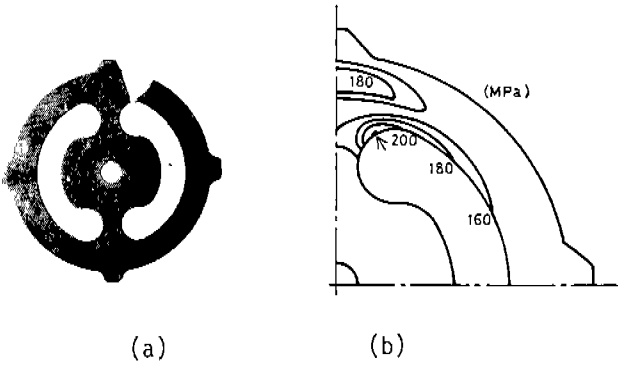

Fig. 5 Comparison of failed valve and stress distribution obtained

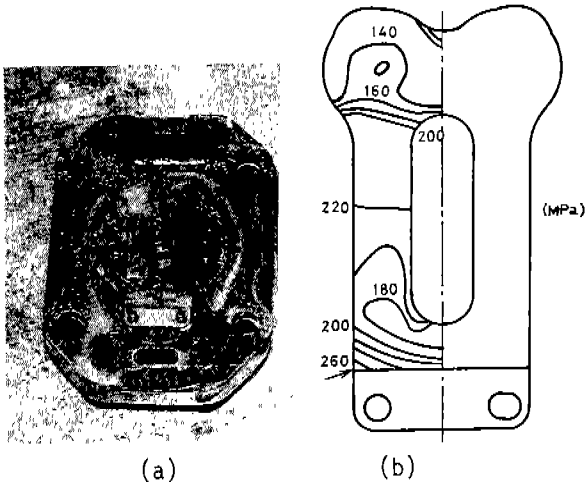

Fig. 6 Comparison of failed valve and stress distribution obtained



Fig. 7 Bar and ring suction valve

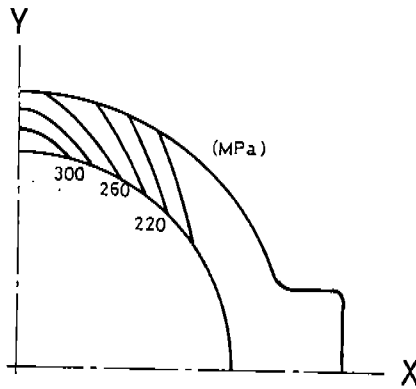

Fig. 8 Stress distribution obtained

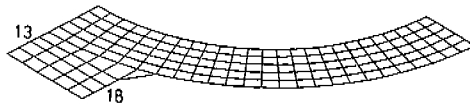

Fig. 9 Finite element mesh

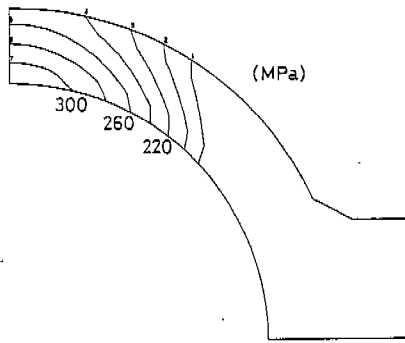

Fig. 10 Maximum shear stress contour



Fig. 11 Deformation contours in z direction

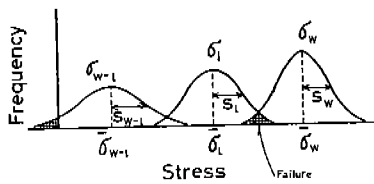

Fig. 12 Overlapping distributions of valve stress and fatigue strength

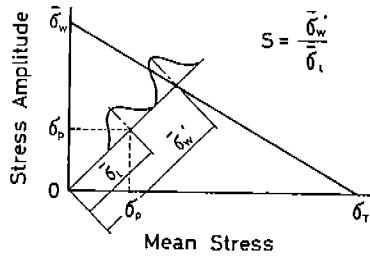

Fig. 13 Modified Goodman diagram

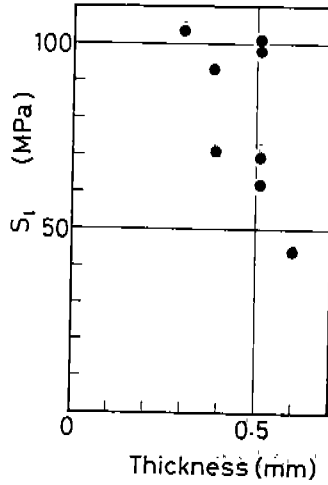

Fig. 14 Relationship between S_1 and valve thickness